

# Syntactic Theory

## Lecture 8a (15.01.2009)

PD Dr. Valia Kordoni

Email: [kordoni@coli.uni-sb.de](mailto:kordoni@coli.uni-sb.de)

<http://www.coli.uni-saarland.de/courses/syntactic-theory-08/>

# Head-Driven Phrase Structure Grammar (HPSG)

## Introduction – Part VIII –

# Unbounded Dependency Constructions

Examples of UDCs:

- (1) *Wh*-questions
  - a. Who<sub>*i*</sub> did the aliens abduct \_\_\_\_<sub>*i*</sub>?
  - b. Kim asked [how many eggs]<sub>*i*</sub> Sandy wanted \_\_\_\_<sub>*i*</sub>.
- (2) Topicalization  
[Someone like Sandy]<sub>*i*</sub>, I wouldn't trust \_\_\_\_<sub>*i*</sub> with my money.
- (3) *It*-clefts  
It was Kim who<sub>*i*</sub> the aliens abducted \_\_\_\_<sub>*i*</sub>.
- (4) Relative clauses
  - a. The people who<sub>*i*</sub> I'm waiting for \_\_\_\_<sub>*i*</sub> are late.
  - b. Kim found what<sub>*i*</sub> Sandy was hiding \_\_\_\_<sub>*i*</sub>.

In Transformational Grammar, analyzed as instances of *wh*-movement ( $\bar{A}$ -movement to [Spec,CP]). Gazdar (1981) showed that UDCs can be handled non-transformationally, using complex categories.

# Filler-gap structures

(5) John, Mary adores \_\_\_\_<sub>*i*</sub>.

The analysis of (strong) UDCs in P&S 94 (Ch. 4) assumes the presence of a **trace** at the “bottom” of the dependency:

(6)

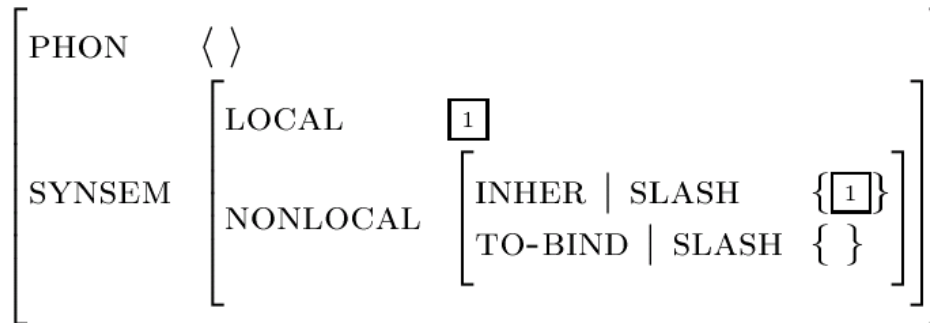

# Filler-gap structures (cont.)

Trace can have any kind of LOCAL value, and this is copied into the INHER | SLASH set. The contents of the INHER | SLASH set are passed up the tree via the NONLOCAL Feature Principle (to be formalized below). As shown below, trace appears as the NP complement of *adores* in (5).

(7) Structure of the VP in sentence (5)

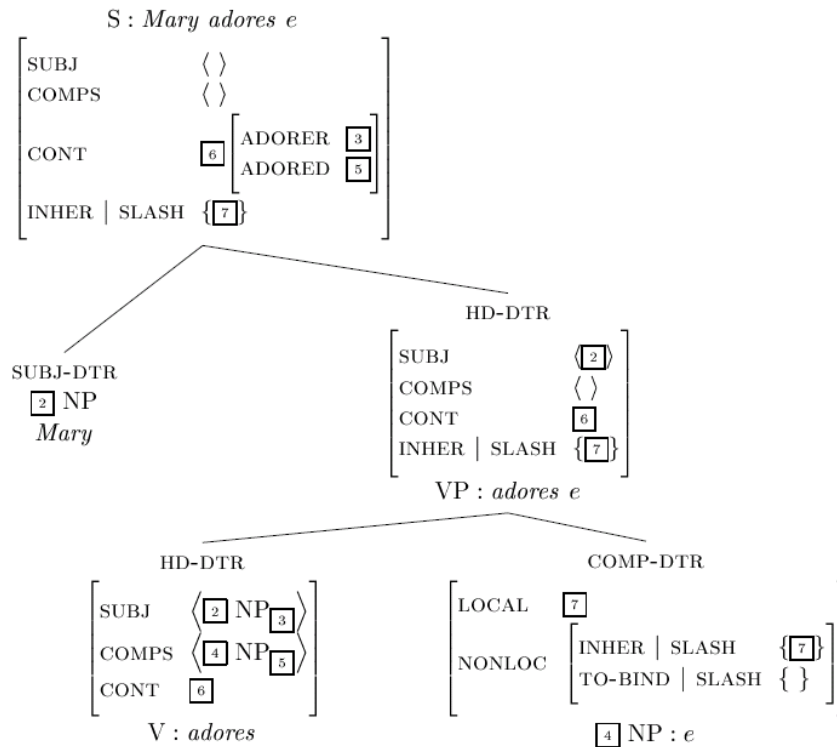

# Filler-gap structures (cont.)

At the top of the tree, the dependency is discharged via the Head-Filler Schema. This is stated as a constraint on the type *head-filler-structure*, a subtype of *construc*:

(8)

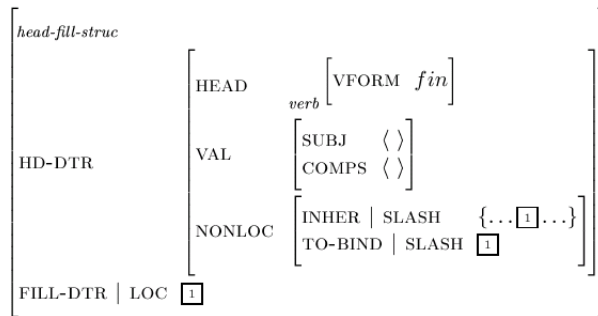

The head daughter is a finite VP with empty valence lists. Its INHER | SLASH set contains a *local* object that is token identical to the single member of its TO-BIND | SLASH set. This *local* object is furthermore token identical to the LOCAL value of the filler daughter.

A head-filler phrase must satisfy all the constraints we have seen so far, in particular the HFP, ValP, and SemP. In addition, it satisfies the NONLOCAL Feature Principle:

(9) For each NONLOCAL feature  $F^1$ , the INHERITED | F value of the mother phrase is the union of the INHER | F values of all the daughters, minus the TO-BIND | F value of the head daughter.

(10) Head-filler phrase, tree notation

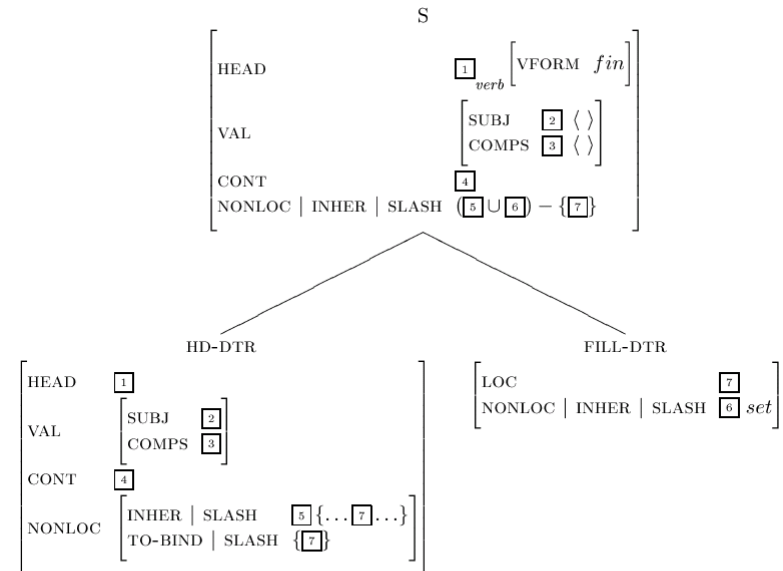

Note: The head daughter's nonempty TO-BIND | SLASH set is freely instantiated. I.e., there is no constraint other than the Head-Filler rule requiring it to be there. Also, it may be desirable to add the requirement [FILL-DTR | INHER | SLASH : { } ] to the rule as stated in (8).

<sup>1</sup>We have seen only one: SLASH. The other two are QUE, used for interrogative *wh*-constructions, and REL, used for relative clauses.

# Filler-gap structures (cont.)

(11) Structure for sentence (5)

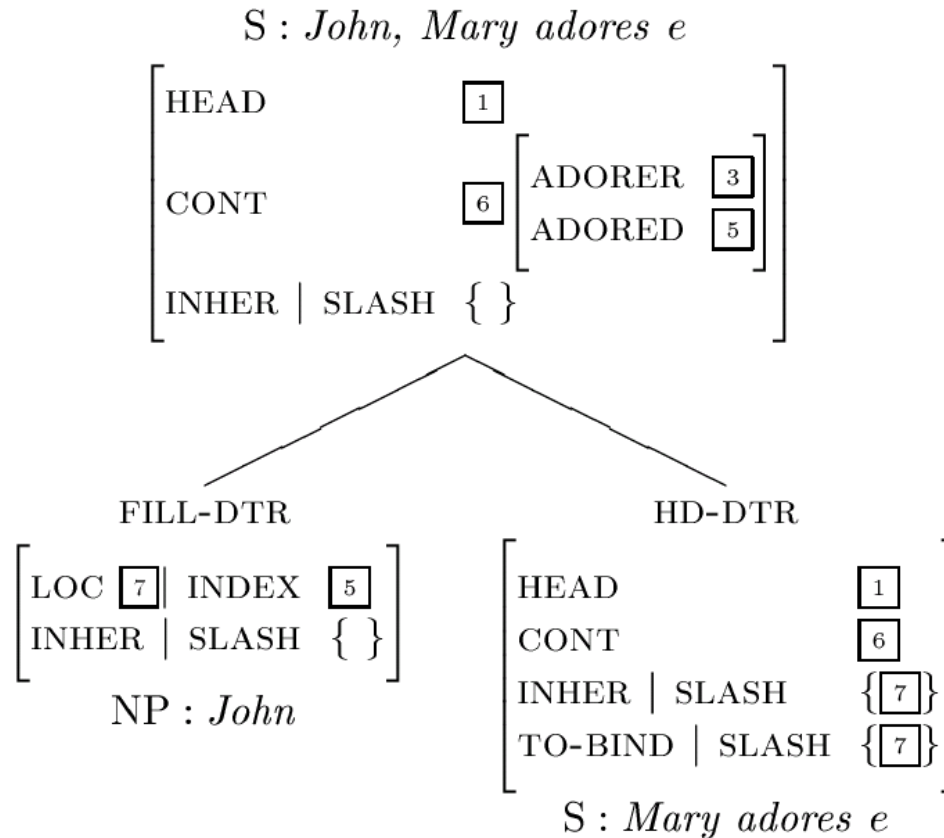

# Traceless extraction

The analysis above closely mirrors the standard transformational account, although the link between the filler and gap is the result of structure sharing rather than movement.

The use of empty categories in linguistic analysis is controversial, however (Pickering & Barry, 1991; Sag & Fodor, 1994), more recent work in HPSG aims to eliminate the use of null elements. The revised approach to UDCs given in P&S 94 (Ch. 9) does not rely on the empty lexical item trace. Instead, heads are assumed to be “SLASHed” via lexical rule:

1087x664

(12) Complement Extraction Lexical Rule (CELR)

$$\left[ \begin{array}{l} \text{COMPS} \quad \langle \dots [\text{LOC } \boxed{1}] \dots \rangle \\ \text{INHER} \mid \text{SLASH } \boxed{2} \text{ set} \end{array} \right] \mapsto \left[ \begin{array}{l} \text{COMPS} \quad \langle \dots \rangle \\ \text{INHER} \mid \text{SLASH } \boxed{2} \cup \{\boxed{1}\} \end{array} \right]$$

Interpretation: a *synsem* object is removed from the head’s COMPS list, and its LOCAL value is moved into the head’s INHER | SLASH set.

# Traceless extraction (cont.)

For example, the verb *adores* can be input to the CELR:

(13)

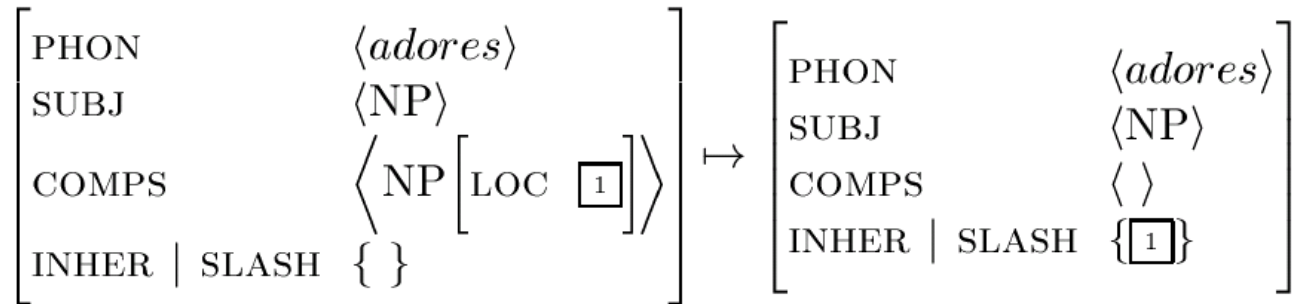

The structure for sentence (5) now involves no complement daughter trace:

(14) Sentence (5), traceless analysis

# Traceless extraction (cont.)

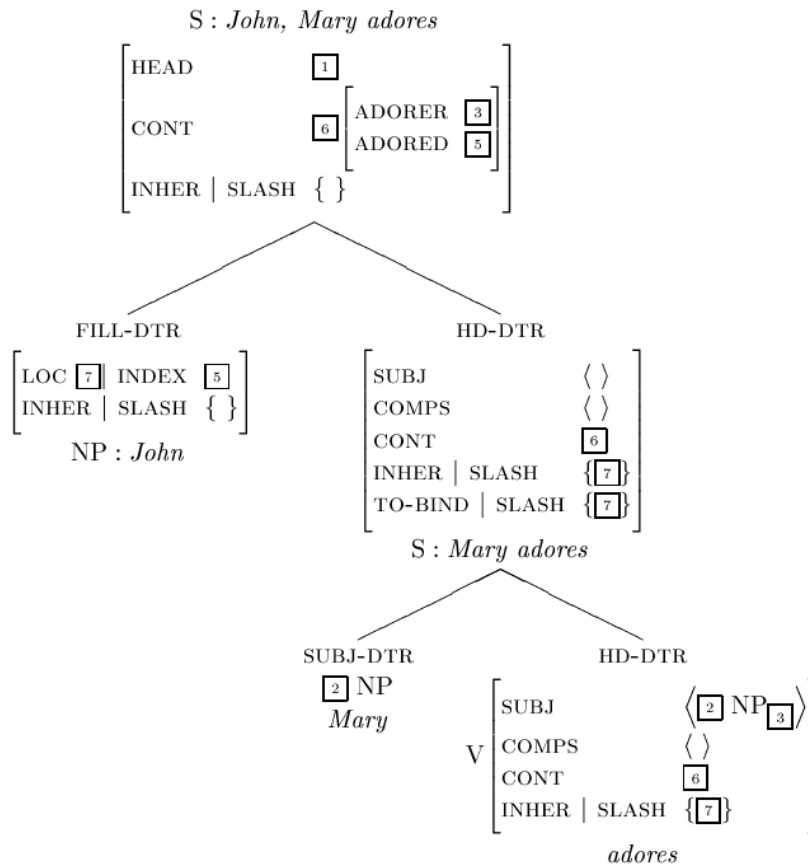

Everything “above” the gap (i.e., the NLFP and Head-Filler Schema) continues to operate as before.

# Traceless extraction (cont.)

The CELR applies to other heads besides verbs:

(15) a. Prepositions

What<sub>*i*</sub> is Kim crying about \_\_\_\_<sub>*i*</sub>?

b. Adjectives

This is a result [of which]<sub>*i*</sub> you can be very proud \_\_\_\_<sub>*i*</sub>.

c. Nouns

[For what flavor of ice cream]<sub>*i*</sub> do you have a craving \_\_\_\_<sub>*i*</sub>?

# Subject Extraction

The CELR only allows dependencies into complement positions. It does not license the following:

- (16) a. Who adores John?  
 b. Who<sub>i</sub> does Kim think \_\_\_\_<sub>i</sub> adores John?

Sentence (16a) is not analyzed as a filler-gap construction in HPSG, but as an ordinary head-subject structure:

- (17) Tree for sentence (16a)

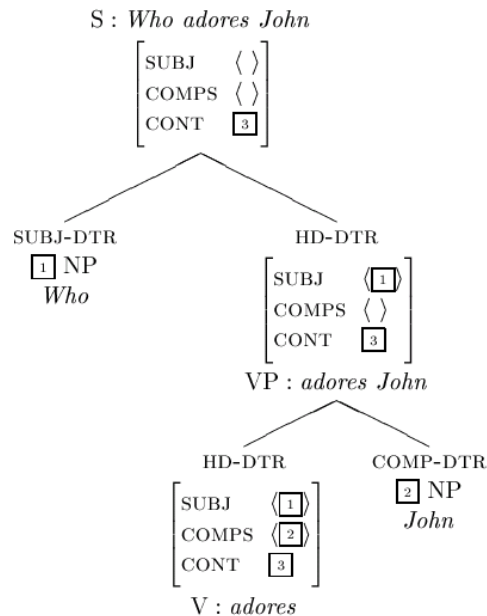

# Subject Extraction (cont.)

Motivation:

- No evidence of *wh*-movement (“vacuous” movement)
- No auxiliary insertion

(18) \* Who does adore John?

On the other hand, there must be an unbounded dependency in (16b), so we need a lexical rule allowing subject extraction, but only out of unmarked embedded clauses:

(19) Subject Extraction Lexical Rule (SELR)

$$\left[ \text{COMPS } \left\langle \dots \left[ \begin{array}{ll} \text{SUBJ} & \langle \rangle \\ \text{MARKING} & \textit{unmarked} \end{array} \right] \dots \right\rangle \right] \mapsto$$
$$\left[ \begin{array}{l} \text{COMPS} \quad \left\langle \dots \left[ \text{SUBJ } \langle [\text{LOC } \boxed{1}] \rangle \right] \dots \right\rangle \\ \text{INHER} \mid \text{SLASH} \quad \{ \boxed{1} \} \end{array} \right]$$

# Subject Extraction (cont.)

This rule applies to the verb *think* in (16b):

(20)

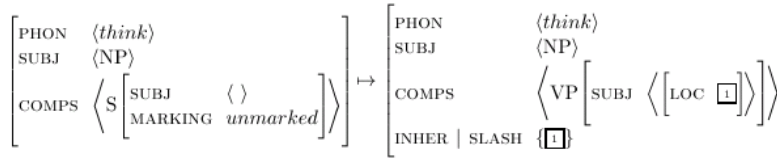

Instead of subcategorizing for an saturated S complement, the output form of the verb selects an unsaturated VP that still lacks a subject. This missing subject's LOCAL value is added to the verb's INHER | SLASH set.

(21) Tree for (16b)

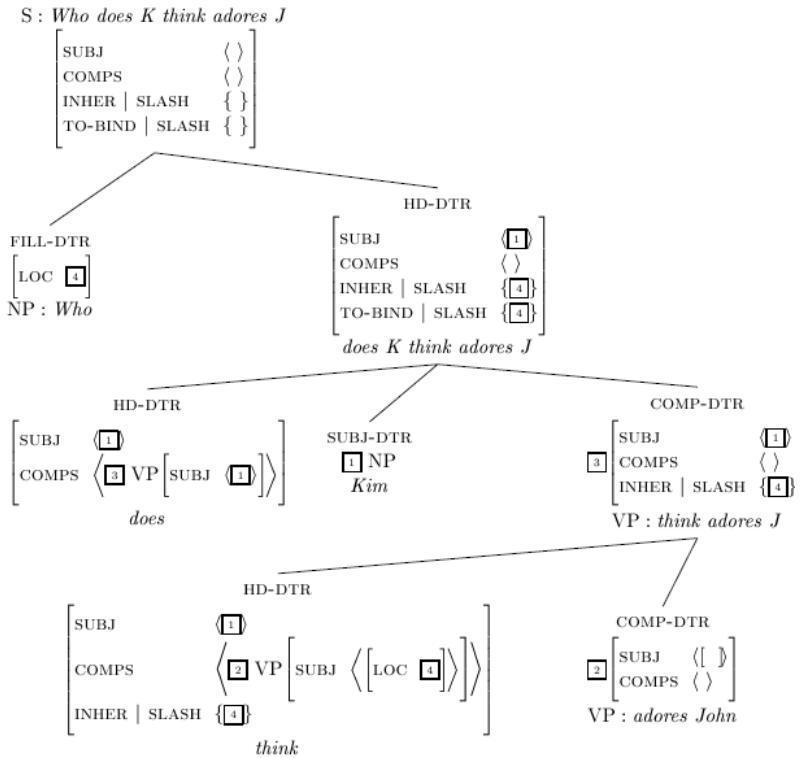

The S[unmarked] requirement in the SELR blocks *that*-trace violations:

- (22) Kim thinks [that Mary adores John].  
 → \*Who<sub>i</sub> does Kim think that \_\_\_\_<sub>i</sub> adores John?

# Adjunct Extraction

Extraction of adjuncts is subject to complicated semantic and pragmatic restrictions, but grammatical examples do seem to exist:

- (23) Kim thinks Mary has adored John for 10 years.  
 → [For how many years]<sub>i</sub> does Kim think Mary has adored John \_\_\_\_<sub>i</sub>?

The following rule will accommodate these constructions:

- (24) Adjunct Extraction Lexical Rule (AELR)

$$\left[ \begin{array}{l} \text{COMPS} \\ \text{CONT} \mid \text{SOA-ARG} \end{array} \left[ \dots \boxed{1} \text{VP} \left[ \begin{array}{l} \text{SUBJ} \langle \rangle \\ \text{CONT} \boxed{2} \end{array} \dots \right] \right] \right] \mapsto \left[ \begin{array}{l} \text{CONT} \mid \text{SOA-ARG} \boxed{3} \\ \text{INHER} \mid \text{SLASH} \left\{ \left[ \begin{array}{l} \text{MOD} \boxed{1} \\ \text{CONT} \boxed{3} \end{array} \right] \right\} \end{array} \right]$$

As in the case of subject extraction, preposing of an adjunct within a single clause is not treated as an unbounded dependency:

- (25) For 10 years, Mary has adored John.

This is treated as an ordinary head-adjunct phrase.

# Tough Constructions

The following examples illustrate another type of UDC:

- (26) a. Sandy<sub>*i*</sub> is impossible (for anyone) to fool \_\_\_\_<sub>*i*</sub>.  
b. Sandy<sub>*i*</sub> is impossible to imagine people succeeding in fooling \_\_\_\_<sub>*i*</sub>.

These cases differ from the UDCs we have seen in two ways:

- There is no (syntactic) filler. The gap in both sentences in (26) is co-indexed with *Sandy*, but *Sandy* is the subject of *is*, and receives a semantic role from *impossible*. In GB terms, *Sandy* is in an A-position, whereas the fillers we saw above were all in  $\bar{A}$ -positions.
- *Tough* constructions are licensed by a particular class of lexical items (not by systematic lexical rules):
  - adjectives like *tough*, *easy*, *nice*
  - nouns like *(a) pleasure*, *(a) bother*
  - verbs like *cost*, *take*

# Tough Constructions (cont.)

The words involved in *tough* constructions are assumed to subcategorize for SLASHed infinitival VP complements:

(27)

PHON	$\langle impossible \rangle$	
HEAD	$\left[ \begin{array}{l} PRD \quad + \\ \text{adj} \end{array} \right]$	
SUBJ	$\langle NP_{[1]} \rangle$	
COMPS	$\langle (PP_{[3]}[for]),$	$\left[ \begin{array}{l} VFORM \quad \text{inf} \\ SUBJ \quad \langle NP_{[3]} \rangle \\ CONT \quad [4] \text{ psoa} \\ INHER \mid SLASH \quad \{ [2] NP[acc] : ppro_{[1]} \} \end{array} \right]$
CONT	$\left[ \begin{array}{l} impossible \\ INST \quad [1] \\ SOA-ARG \quad [4] \end{array} \right]$	VP
TO-BIND   SLASH	$\{ [2] \}$	$\rangle$

In our example above in (26a), the embedded VP *to fool* is required to contain an NP[acc] gap.<sup>2</sup> By applying the CELR to the verb *fool*, we obtain the following structure:

(28) Structure for the complement VP in (26a)

<sup>2</sup>The *ppro* requirement means that the gap must behave like a personal pronoun for binding purposes. We will return to this when we look at HPSG Binding Theory.

# Tough Constructions (cont.)

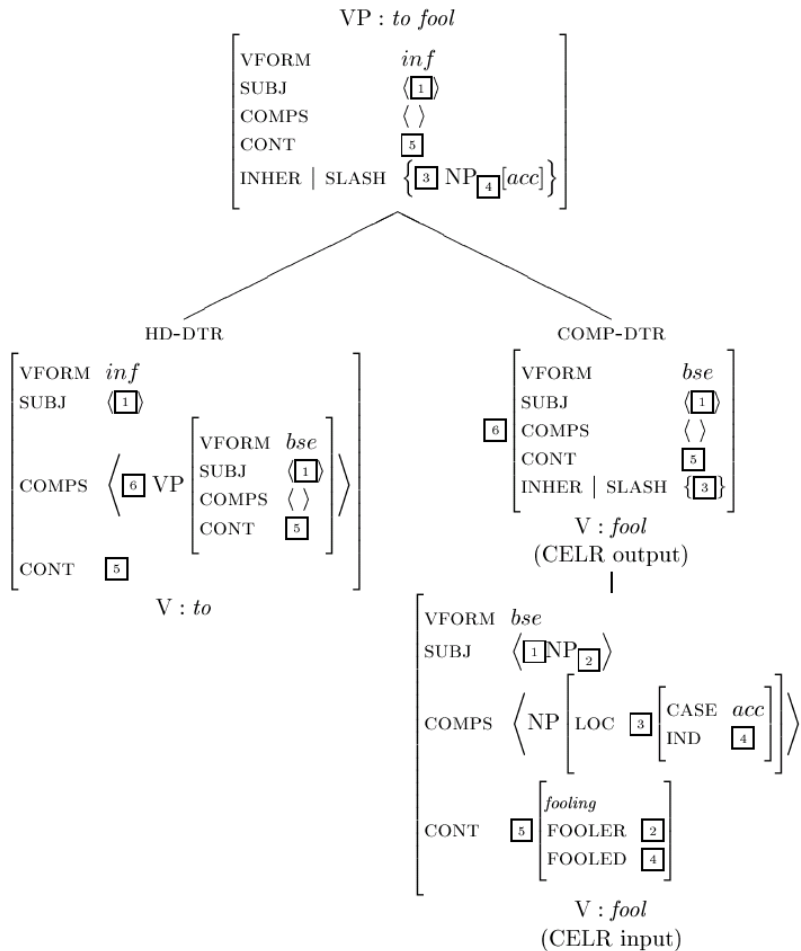



# Tough Constructions (cont.)

The TO-BIND | SLASH specification in the entry for *impossible* ensures that the dependency is terminated at the level of the AdjP (via the Head-Complement rule, not the Head-Filler Rule). The link between *Sandy* and the missing NP is a matter of shared INDEX values, not shared LOCAL values (as in a filler-gap construction). Therefore, the case mismatch in the following example is (correctly) licensed:

(30) [I-*nom*]<sub>i</sub> am impossible to fool \_\_\_\_-*acc*<sub>i</sub>.

# References

- Bouma, G., Malouf, R., & Sag, I. (1998). A unified theory of complement, adjunct, and subject extraction. In G. Bouma, G.-J. M. Kruijff, & R. T. Oehrle (Eds.), *Proceedings of the joint conference on Formal Grammar, Head-Driven Phrase Structure Grammar, and Categorical Grammar* (pp. 83–97). Saarbrücken: .
- Gazdar, G. (1981). Unbounded dependencies and coordinate structure. *Linguistic Inquiry*, 12, 155-184.
- Pickering, M., & Barry, G. (1991). Sentence processing without empty categories. *Language and Cognitive Processes*, 6, 229–259.
- Sag, I. A. (1997). English relative clause constructions. *Journal of Linguistics*, 33, 431–484.
- Sag, I. A., & Fodor, J. D. (1994). Extraction without traces.