

Semantic Theory

Week 9 – Discourse Representation Theory

Noortje Venhuizen

Universität des Saarlandes

Summer 2018

Recap: DRS Syntax

A discourse representation structure (DRS) K is a pair $\langle U_K, C_K \rangle$, where:

- $U_K \subseteq U_D$ and U_D is a set of discourse referents, and
- C_K is a set of well-formed DRS conditions

Well-formed DRS conditions:

- $R(u_1, \dots, u_n)$ *where:* R is an n -place relation, $u_i \in U_D$
- $u = v$ $u, v \in U_D$
- $u = a$ $u \in U_D$, a is a constant
- $\neg K_1$ K_1 is a DRS
- $K_1 \Rightarrow K_2$ K_1 and K_2 are DRSs
- $K_1 \vee K_2$ K_1 and K_2 are DRSs

Anaphora and accessibility

Mary knows a professor. If she owns a book, he reads it. ?It fascinates him.

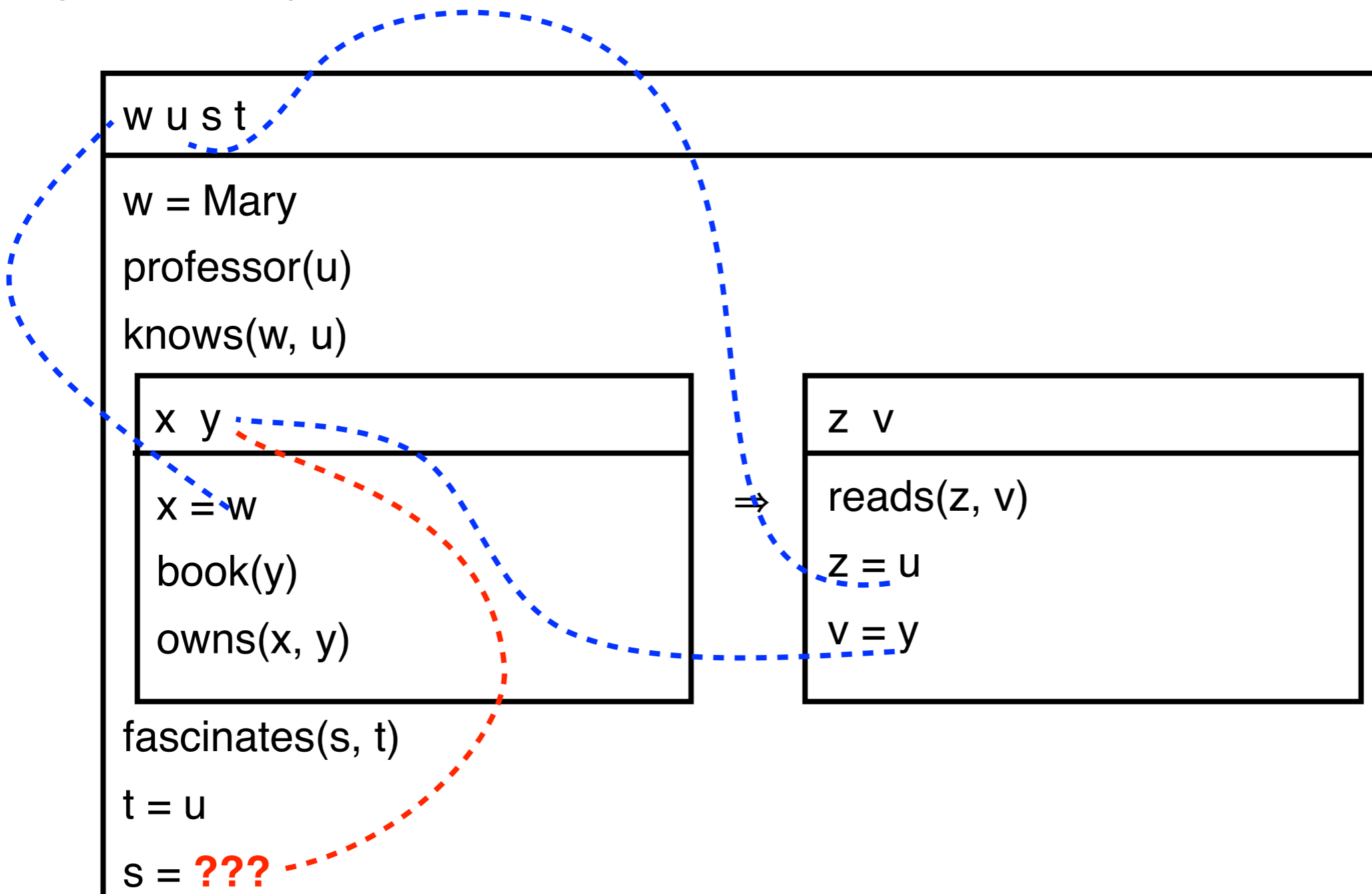

Non-accessible discourse referents

Cases of non-accessibility:

- (1) *If a professor owns a book, he reads it. It has 300 pages.*
- (2) *It is not the case that a professor owns a book. He reads it.*
- (3) *Every professor owns a book. He reads it.*
- (4) *If every professor owns a book, he reads it.*
- (5) *Peter owns a book, or Mary reads it.*
- (6) *Peter reads a book, or Mary reads a newspaper article. It is interesting.*

Accessible discourse referents

The following discourse referents are accessible for a condition:

- DRs in the same local DRS
- DRs in a superordinate DRS
- DRs in the universe of an antecedent DRS, if the condition occurs in the consequent DRS.

We need a formal notion of DRS subordination

Subordination

A DRS K_1 is an immediate sub-DRS of a DRS $K = \langle U_K, C_K \rangle$ iff C_K contains a condition of the form

- $\neg K_1, K_1 \Rightarrow K_2, K_2 \Rightarrow K_1, K_1 \vee K_2$ or $K_2 \vee K_1$.

K_1 is a sub-DRS of K (notation: $K_1 \leq K$) iff

- $K_1 = K$, or
- K_1 is an immediate sub-DRS of K , or
- there is a DRS K_2 such that $K_1 \leq K_2$ and K_2 is an immediate sub-DRS of K (i.e. reflexive, transitive closure)

K_1 is a proper sub-DRS of K iff $K_1 \leq K$ and $K_1 \neq K$.

Accessibility

Let K, K_1, K_2 be DRSs such that $K_1, K_2 \leq K, x \in U_{K_1}, \gamma \in C_{K_2}$

x is accessible from γ in K iff

- $K_2 \leq K_1$ or
- there are $K_3, K_4 \leq K$ such that $K_1 \Rightarrow K_3 \in C_{K_4}$ and $K_2 \leq K_3$

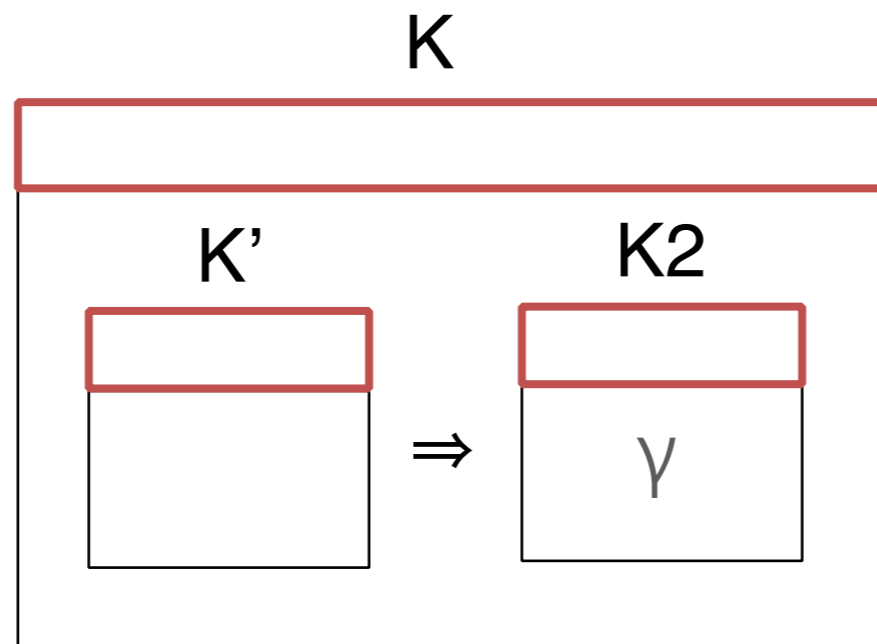

Free and bound variables in DRT

A DRS variable x , introduced in DRS K_1 , is bound in global DRS K iff there exists a DRS $K_j \leq K$, such that:

- (i) $K_i \leq K_j$;
- (ii) $x \in U(K_j)$.

Properness: A DRS is *proper* iff it does not contain any free variables

Purity: A DRS is *pure* iff it does not contain any *otiose declarations* of variables

$$x \in U(K_1) \text{ and } x \in U(K_2) \text{ and } K_1 \leq K_2$$

From text to DRS

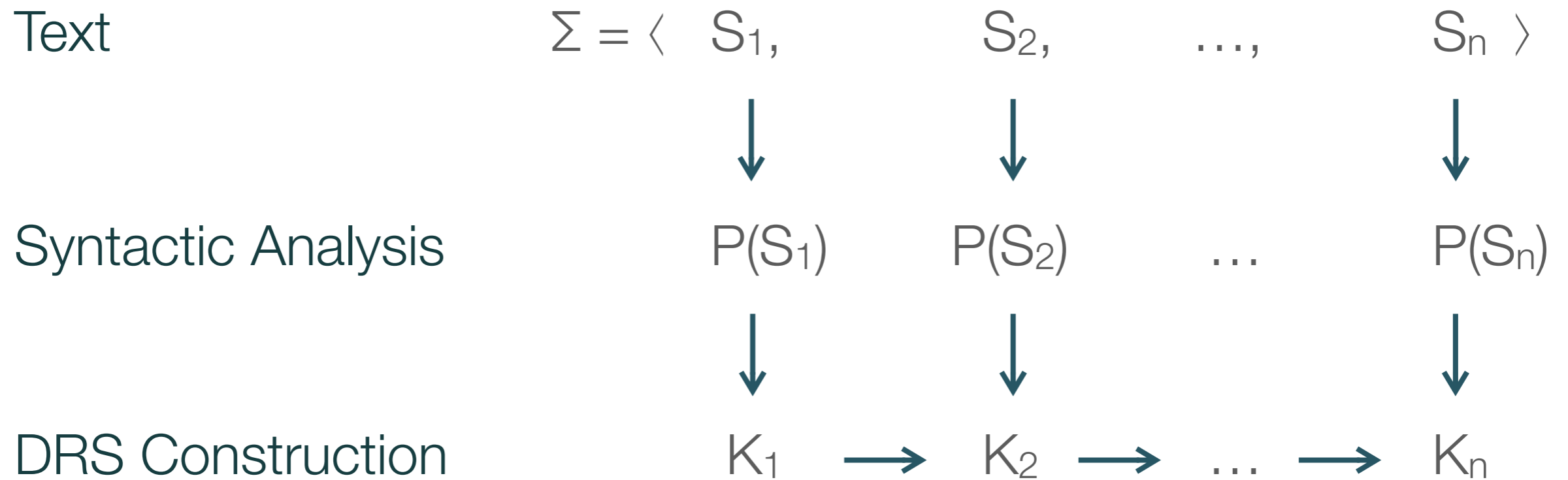

DRS Construction Algorithm

Let the following be a well-formed, *reducible* DRS condition:

- Conditions of form α or $\alpha(x_1, \dots, x_n)$, where α is a context-free parse tree.

DRS construction algorithm:

- Given a text $\Sigma = \langle S_1, \dots, S_n \rangle$, and a DRS $K_0 (= \langle \emptyset, \emptyset \rangle)$, by default
- Repeat for $i = 1, \dots, n$:
 - Add parse tree $P(S_i)$ to the conditions of K_{i-1} .
 - Apply DRS construction rules to reducible conditions of K_{i-1} , until no reduction steps are possible any more.
 - The resulting DRS K_i is the discourse representation of text $\langle S_1, \dots, S_i \rangle$.

DRS Construction Example

- A farmer owns a donkey. He beats it.

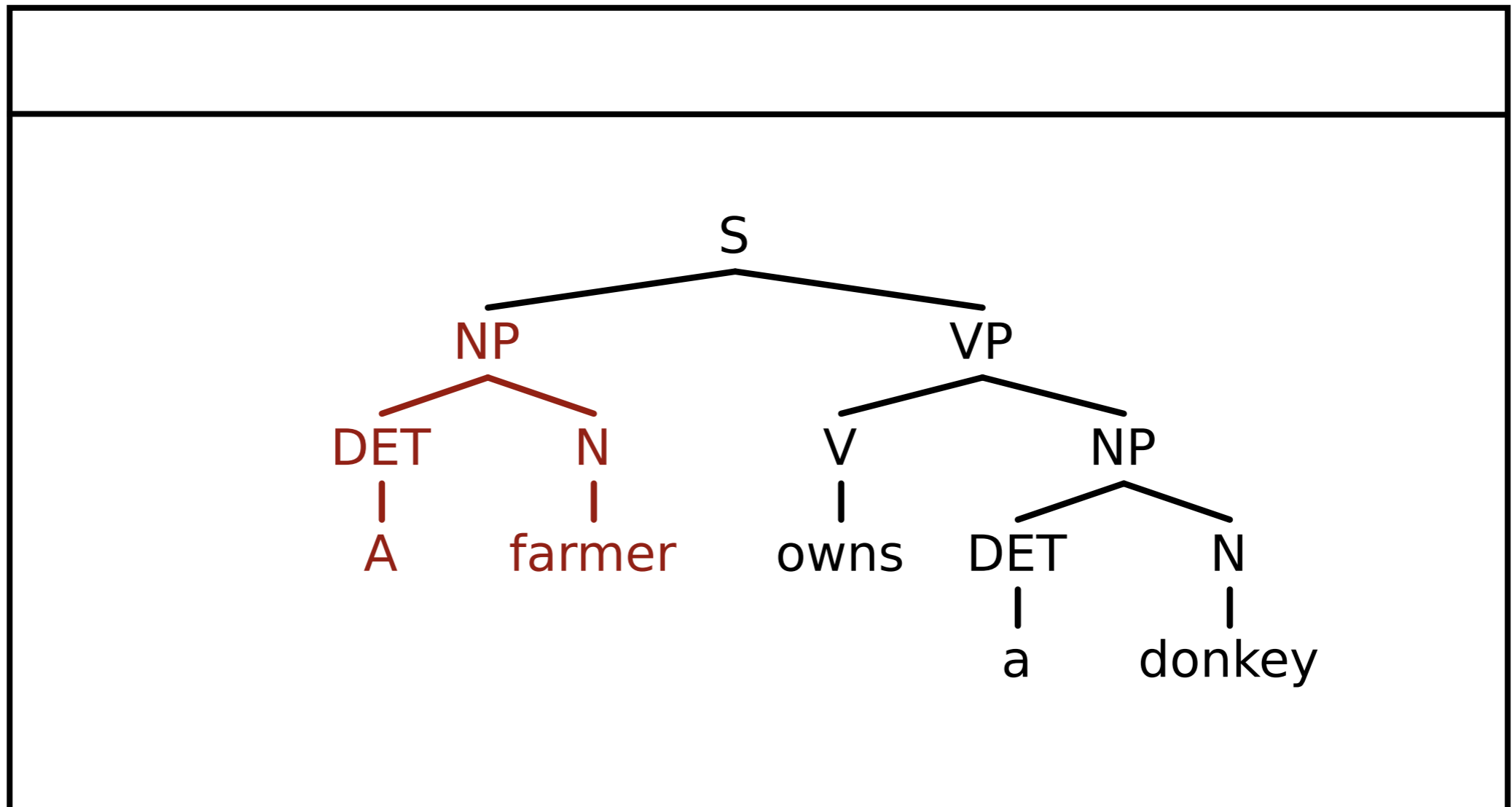

DRS Construction Example

- A farmer owns a donkey. He beats it.

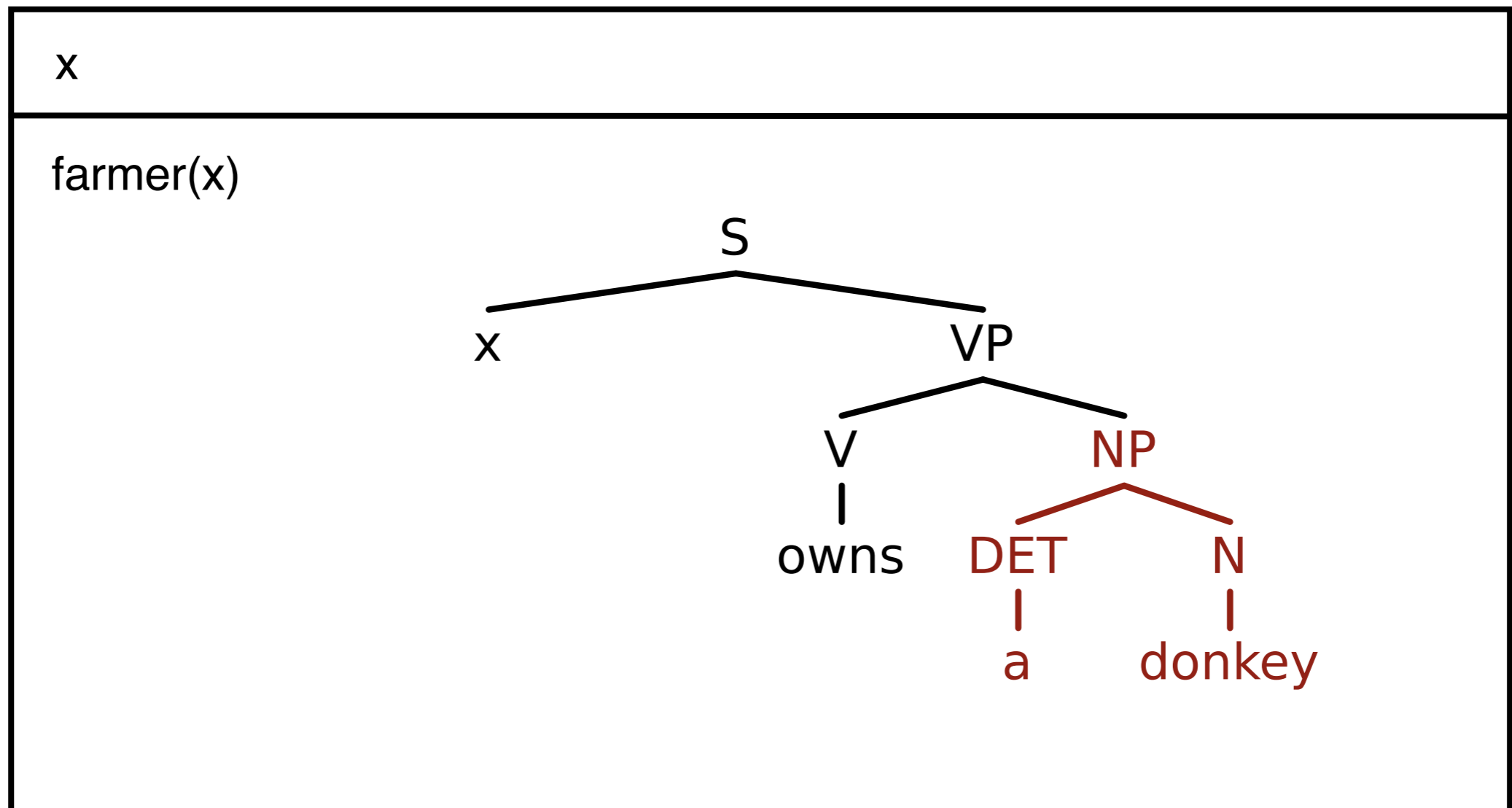

DRS Construction Example

- A farmer owns a donkey. He beats it.

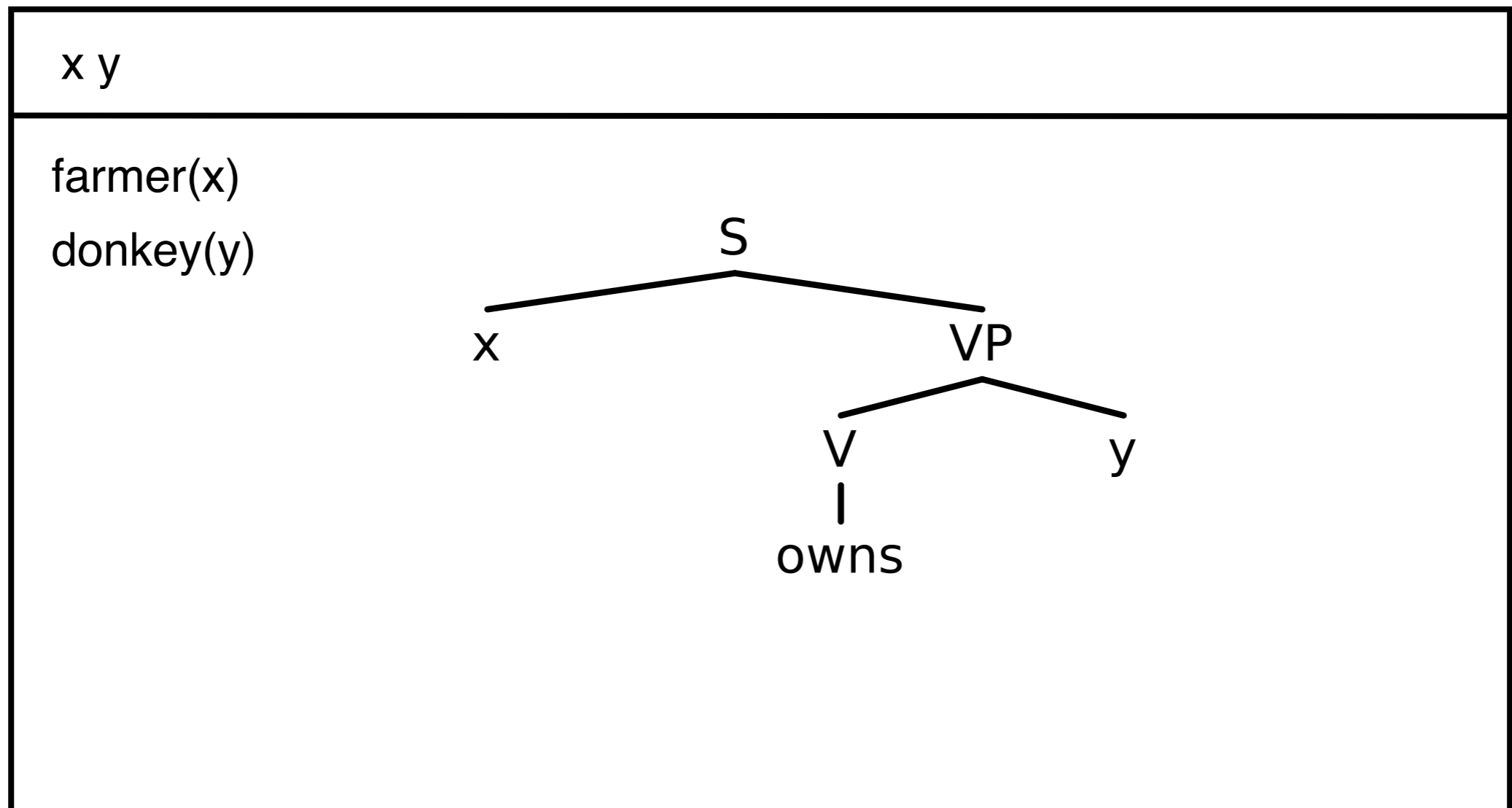

DRS Construction Example

- A farmer owns a donkey. He beats it.

x y
farmer(x) donkey(y) owns(x, y)

DRS Construction Example

- A farmer owns a donkey. He beats it.

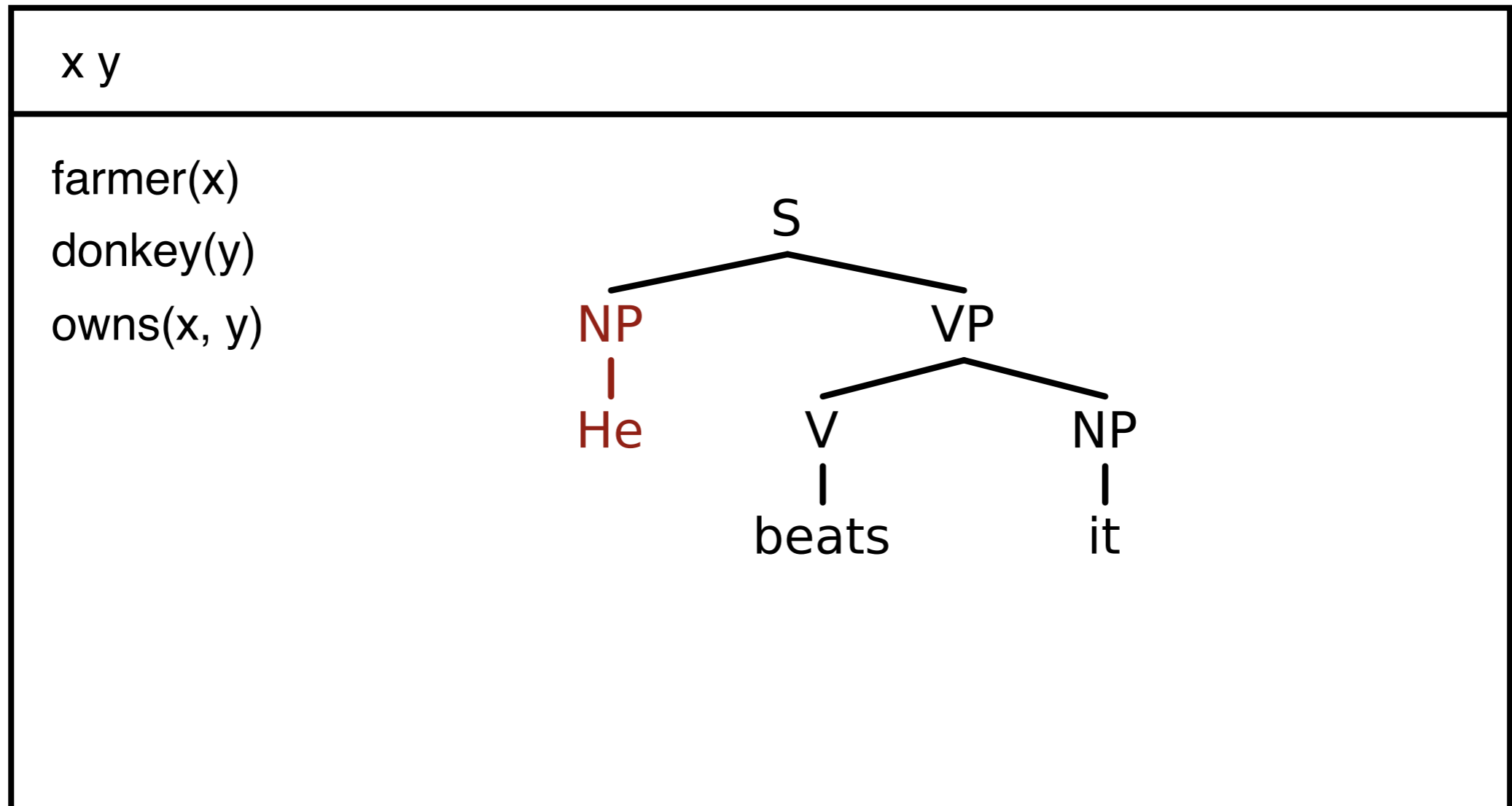

DRS Construction Example

- A farmer owns a donkey. He beats it.

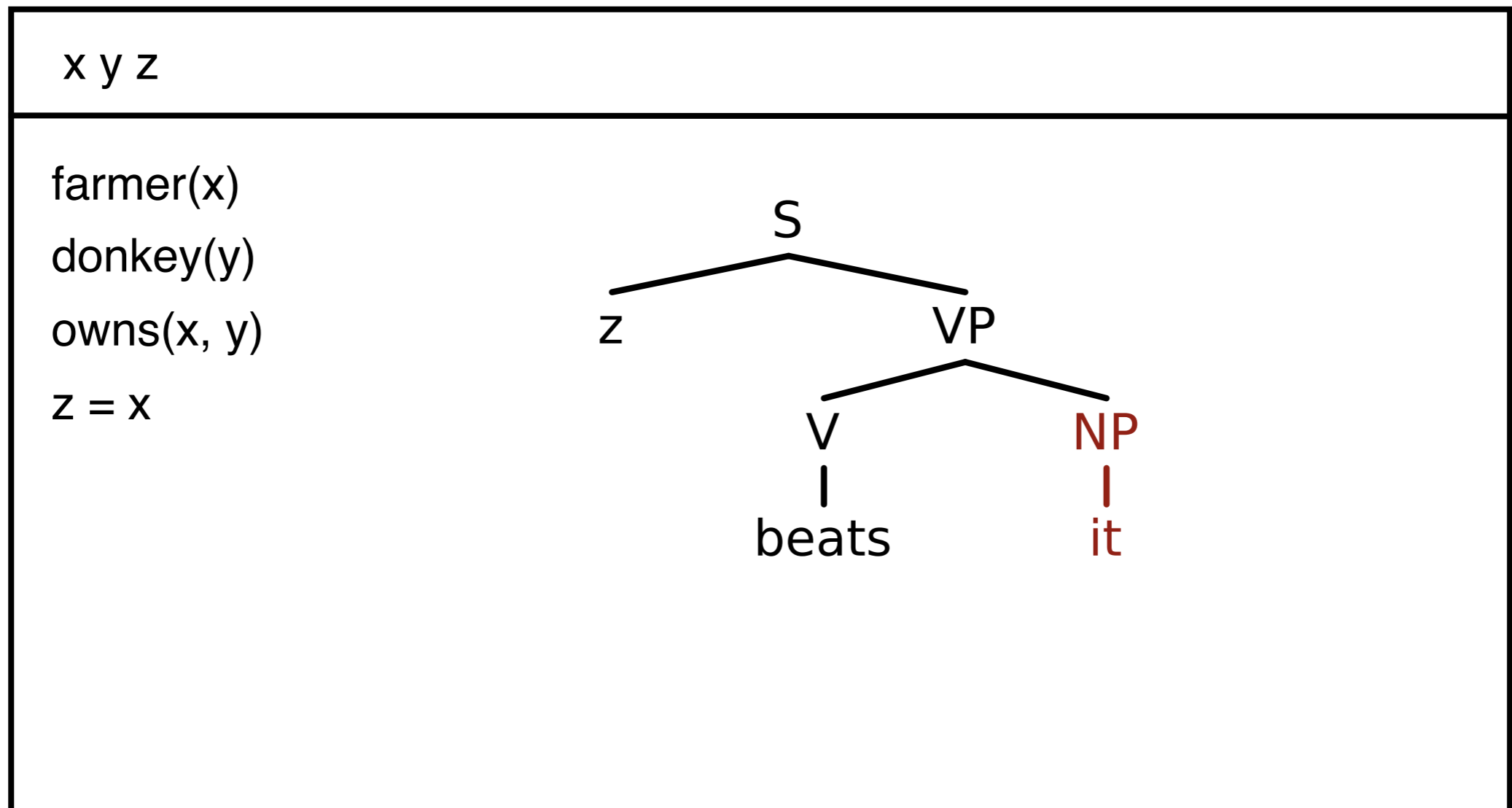

DRS Construction Example

- A farmer owns a donkey. He beats it.

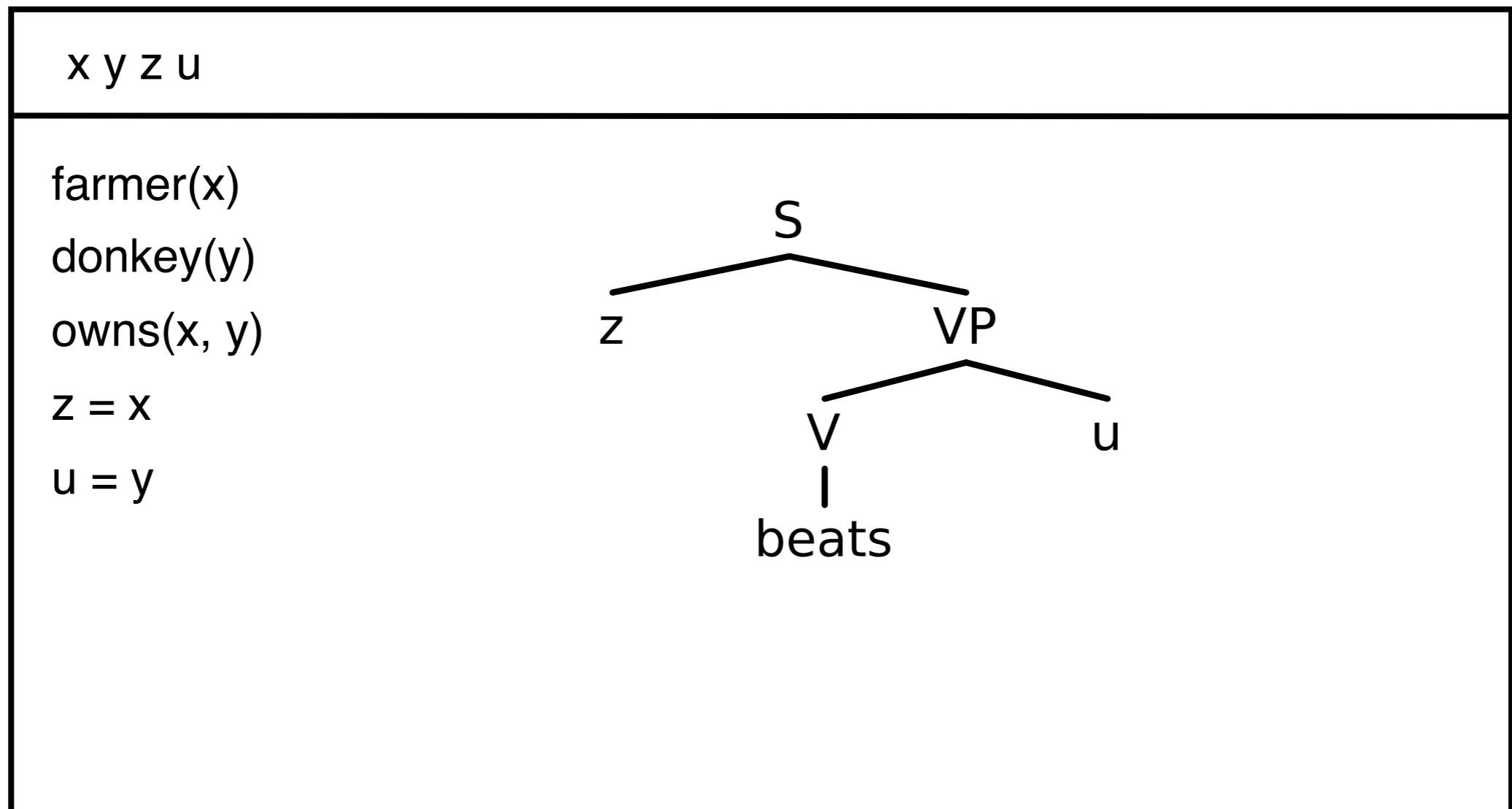

DRS Construction Example

- A farmer owns a donkey. He beats it.

x y z u
farmer(x) donkey(y) owns(x, y) z = x u = y beat(z, u)

Construction Rules: Examples

Indefinite NPs

- **Trigger:** a reducible condition α in DRS K that has a substructure $[\text{NP } \beta]$, such that β is $\varepsilon\delta$, where ε is an indefinite article
- **Action:** Add new DR x to U_K ; Replace β in α by x ; Add $\delta(x)$ to C_K

Personal Pronouns

- **Trigger:** a global DRS K^* , and some $K \leq K^*$, with a reducible condition α in K that has substructure $[\text{NP } \beta]$, such that β is a personal pronoun
- **Action:** Add a new DR x to U_K ; Replace β in α by x ; Select an appropriate DR y that is accessible from α in K^* ; Add $x = y$ to C_K

A constraint on DRS construction

Problem: The basic DRS construction algorithm can derive DRSs for both of the following sentences, with the indicated anaphoric binding:

- (1) [A professor]_i recommends a book that she_i likes
- (2) She_i recommends a book that [a professor]_i likes

Solution: If two different triggering configurations occur in a reducible condition, then first apply the construction rule to the highest triggering configuration.

- *The highest triggering configuration* is the one whose top node dominates the top nodes of all other triggering configurations.

From text to DRS

Text

$\Sigma = \langle S_1, S_2, \dots, S_n \rangle$



Syntactic Analysis

$P(S_1)$

$P(S_2)$

...

$P(S_n)$



DRS Construction

K_1



K_2



...



K_n



Interpretation by
model embedding:
Truth-conditions of Σ

DRS Interpretation

Given a DRS $K = \langle U_K, C_K \rangle$, with $U_K \subseteq U_D$

Let $M = \langle U_M, V_M \rangle$ be a FOL model structure appropriate for K , i.e. a model structure that provides interpretations for all predicates and relations occurring in K

DRS K is *true* in model M *iff*

- there is an **embedding function** for K in M which verifies all conditions in K

... where: an embedding of K into M is a (partial) function \mathbf{f} from U_D to U_M such that $U_K \subseteq \text{Dom}(\mathbf{f})$.

Verifying embedding

An embedding \mathbf{f} of K in M **verifies K in M** ($\mathbf{f} \models_M K$) iff \mathbf{f} verifies every condition $a \in C_K$

- $\mathbf{f} \models_M R(x_1, \dots, x_n)$ iff $\langle \mathbf{f}(x_1), \dots, \mathbf{f}(x_n) \rangle \in V_M(R)$
- $\mathbf{f} \models_M x = y$ iff $\mathbf{f}(x) = \mathbf{f}(y)$
- $\mathbf{f} \models_M x = a$ iff $\mathbf{f}(x) = V_M(a)$
- $\mathbf{f} \models_M \neg K_1$ iff there is no $\mathbf{g} \supseteq_{U_{K_1}} \mathbf{f}$ such that $\mathbf{g} \models_M K_1$
- $\mathbf{f} \models_M K_1 \Rightarrow K_2$ iff for all $\mathbf{g} \supseteq_{U_{K_1}} \mathbf{f}$ such that $\mathbf{g} \models_M K_1$
there is a $\mathbf{h} \supseteq_{U_{K_2}} \mathbf{g}$ such that $\mathbf{h} \models_M K_2$
- $\mathbf{f} \models_M K_1 \vee K_2$ iff there is a $\mathbf{g}_1 \supseteq_{U_{K_1}} \mathbf{f}$ such that $\mathbf{g}_1 \models_M K_1$
or there is a $\mathbf{g}_2 \supseteq_{U_{K_2}} \mathbf{f}$ such that $\mathbf{g}_2 \models_M K_2$

Verifying embedding: example

Mary knows a professor. If he owns a book, he gives it to a student.

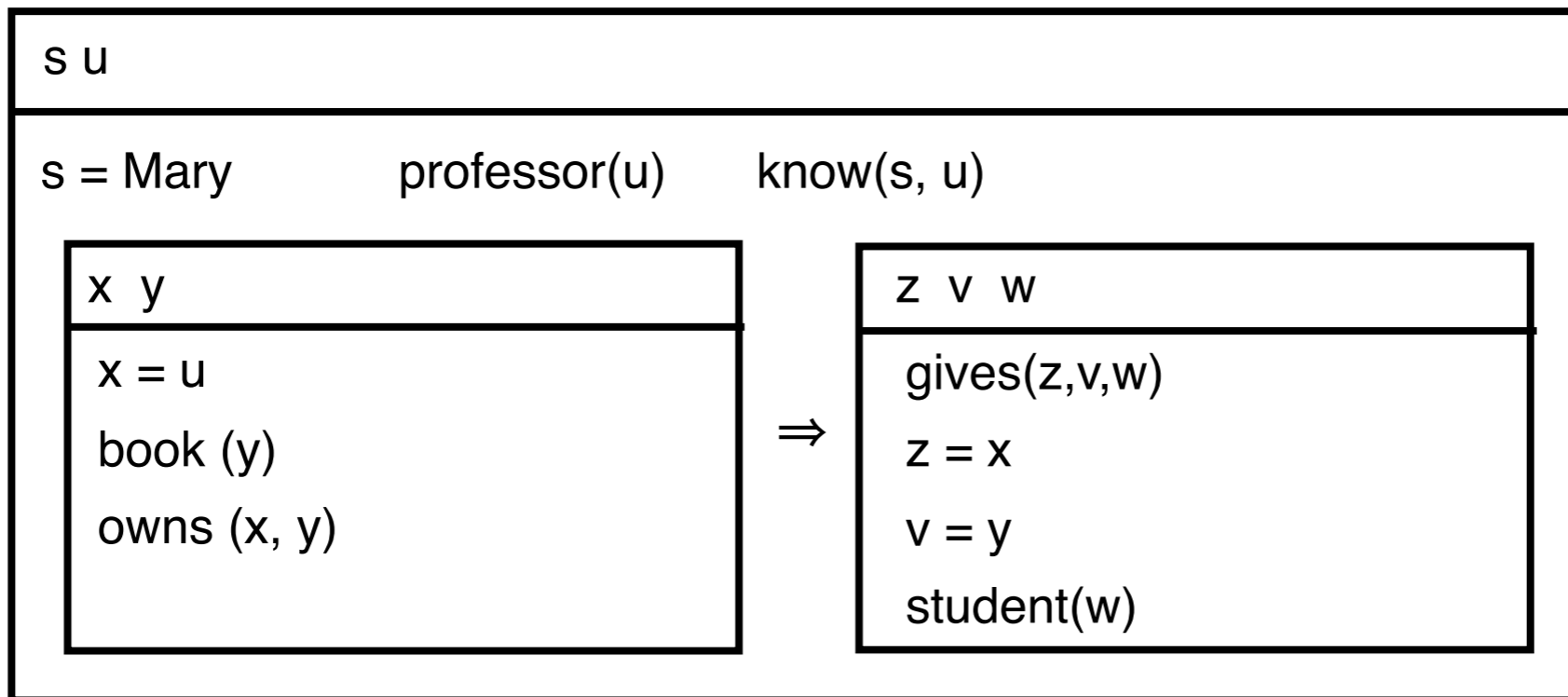

...is **true** in $M = \langle U_M, V_M \rangle$ iff there is an $\mathbf{f} :: U_D \rightarrow U_M$, (with $\{s,u\} \subseteq \text{Dom}(\mathbf{f})$) such that:

$\mathbf{f}(s) = V_M(\text{Mary})$ & $\mathbf{f}(u) \in V_M(\text{prof})$ & $\langle \mathbf{f}(s), \mathbf{f}(u) \rangle \in V_M(\text{know})$,

and for all $\mathbf{g} \supseteq_{\{x,y\}} \mathbf{f}$ s.t. $\mathbf{g}(x) = \mathbf{g}(u)$ ($=\mathbf{f}(u)$) & $\mathbf{g}(y) \in V_M(\text{book})$ & $\langle \mathbf{g}(x), \mathbf{g}(y) \rangle \in V_M(\text{own})$,

there is a $\mathbf{h} \supseteq_{\{z,v,w\}} \mathbf{g}$ s.t. $\langle \mathbf{h}(z), \mathbf{h}(v), \mathbf{h}(w) \rangle \in V_M(\text{give})$ & $\mathbf{h}(z) = \mathbf{h}(x)$ ($=\mathbf{g}(x)$) & ... etc.

Translation of DRSs to FOL

Consider DRS $K = \langle \{x_1, \dots, x_n\}, \{c_1, \dots, c_k\} \rangle$

$x_1 \dots x_n$
c_1 \vdots c_n

K is truth-conditionally equivalent to the following FOL formula:

$$\exists x_1 \dots \exists x_n [c_1 \wedge \dots \wedge c_k]$$

DRT and compositionality

- DRT is non-compositional on truth conditions: The difference in discourse-semantic status of the text pairs is not predictable through the (identical) truth conditions of its component sentences.
- Since structural information which cannot be reduced to truth conditions is required to compute the semantic value of texts, DRT is called a *representational* theory of meaning.

However...

Wait a minute ...

- Why can't we just combine type theoretic semantics and DRT?
- Use λ -abstraction and reduction as we did before, but:
- Assume that the target representations which we want to arrive at are not First-Order Logic formulas, but DRSs.
- The result is called λ -DRT.

λ -DRSs

An expression in λ -DRT consists of a lambda prefix and a partially instantiated DRS.

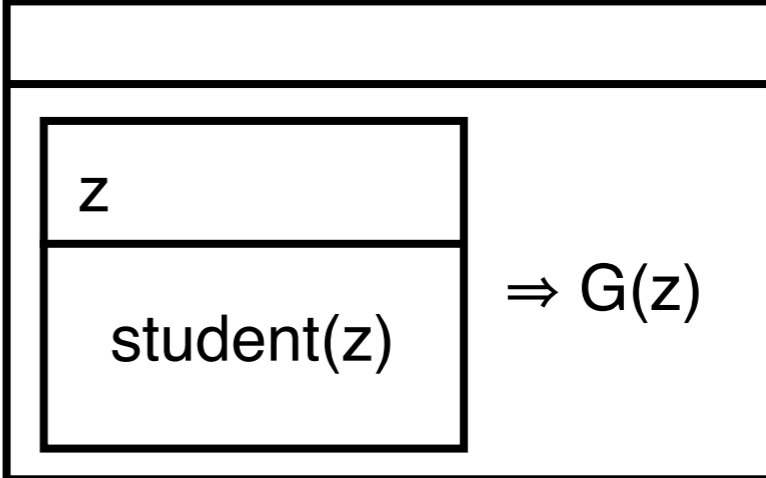
- $every\ student :: \langle \langle e, t \rangle, t \rangle \mapsto \lambda G.$ The diagram shows a lambda-DRS structure. It consists of an outer box representing the DRS. Inside this box, there is a smaller box representing the condition. The condition box is divided into two horizontal sections: the top section contains the variable 'z', and the bottom section contains the predicate 'student(z)'. To the right of the condition box, there is an implication symbol followed by 'G(z)'. The lambda prefix '\lambda G.' is positioned to the left of the outer box.

Alternative notation: $\lambda G [\emptyset \mid [z \mid student(z)] \Rightarrow G(z)]$

- $works :: \langle e, t \rangle \mapsto \lambda x [\emptyset \mid work(x)]$

λ -DRT: β -reduction

Every student works

$$\mapsto \lambda G [\emptyset \mid [z \mid \text{student}(z)] \Rightarrow G(z)] (\lambda x [\emptyset \mid \text{work}(x)])$$

$$\Rightarrow^{\beta} [\emptyset \mid [z \mid \text{student}(z)] \Rightarrow (\lambda x [\emptyset \mid \text{work}(x)])(z)]$$

$$\Rightarrow^{\beta} [\emptyset \mid [z \mid \text{student}(z)] \Rightarrow [\emptyset \mid \text{work}(z)]]$$

How do we define conjunction on DRSs?

(Naïve) Merge

The “merge” operation on DRSs combines two DRSs (conditions and universes).

- Let $K_1 = [U_1 \mid C_1]$ and $K_2 = [U_2 \mid C_2]$.

Merge: $K_1 + K_2 = [U_1 \cup U_2 \mid C_1 \cup C_2]$

Merge: An example

- *a student* $\mapsto \lambda G ([z \mid \text{student}(z)] + G(z))$
- *works* $\mapsto \lambda x [\emptyset \mid \text{work}(x)]$

A student works $\mapsto \lambda G ([z \mid \text{student}(z)] + G(z)) (\lambda x [\emptyset \mid \text{work}(x)])$

$\Rightarrow^\beta [z \mid \text{student}(z)] + \lambda x [\emptyset \mid \text{work}(x)](z)$

$\Rightarrow^\beta [z \mid \text{student}(z)] + [\emptyset \mid \text{work}(z)]$

$\Rightarrow^\beta [z \mid \text{student}(z), \text{work}(z)]$

Compositional analysis

- *Mary* $\mapsto \lambda G ([z \mid z = \text{Mary}] + G(z))$
- *she* $\mapsto \lambda G.G(z)$

Mary works. She is successful.

$\mapsto \lambda K \lambda K' (K + K') ([z \mid z = \text{Mary}, \text{work}(z)]) ([\mid \text{successful}(z)])$

$\Rightarrow^\beta \lambda K' ([z \mid z = \text{Mary}, \text{work}(z)] + K') ([\mid \text{successful}(z)])$

$\Rightarrow^\beta [z \mid z = \text{Mary}, \text{work}(z)] + ([\mid \text{successful}(z)])$

$\Rightarrow^\beta [z \mid z = \text{Mary}, \text{work}(z), \text{successful}(z)]$

Merge again

The “merge” operation on DRSs combines two DRSs (conditions and universes).

- Let $K_1 = [U_1 \mid C_1]$ and $K_2 = [U_2 \mid C_2]$.

Merge: $K_1 + K_2 \Rightarrow [U_1 \cup U_2 \mid C_1 \cup C_2]$

under the assumption that no discourse referent $u \in U_2$ occurs free in a condition $\gamma \in C_1$.

Variable capturing

In λ -DRT, discourse referents are captured via the interaction of β -reduction and DRS-binding:

- $\lambda K'([z \mid \text{student}(z), \text{work}(z)] + K')([\mid \text{successful}(z)])$
 $\Rightarrow^\beta [z \mid \text{student}(z), \text{work}(z)] + [\mid \text{successful}(z)]$
 $\Rightarrow^\beta [z \mid \text{student}(z), \text{work}(z), \text{successful}(z)]$

But the β -reduced DRS must still be *equivalent* to the original DRS!

So, the potential for capturing discourse referents must be captured into the interpretation of a λ -DRS. Possible, but tricky.

Literature

Reading:

- Hans Kamp and Uwe Reyle: From Discourse to Logic, Kluwer: Dordrecht 1993.

Link:

- <https://plato.stanford.edu/entries/discourse-representation-theory/>