



Einführung in Pragmatik und Diskurs

Presuppositions (cont.)

Ivana Kruijff-Korbayová
korbay@coli.uni-sb.de
<http://www.coli.uni-saarland.de/courses/pd/>

Summer Semester 2005



Semantic Theories of Presuppositions

Attempt to handle presupposition within truth-conditional semantic theory, as a special kind of entailment (Folgerung).

Sentence ϕ **semantically presupposes** a sentence ψ iff:

- (i) $\phi \models \psi$
- (ii) $\neg \phi \models \psi$

where $\phi \models \psi$ stands for **semantic entailment**:

Sentence ϕ **semantically entails** a sentence ψ iff:
every situation that makes ϕ true, makes ψ true
(or: in all worlds in which ϕ is true, ψ is also true)

Cont'd

2



Semantic Presupposition

Semantic theories of presuppositions require some fundamental changes in the kind of logic used to model NL semantics.

Why?

- to handle presupposition failure
- to handle presupposition "cancellation" in context

Solutions:

- multi-valued logics (truth-values: true, false and neither-true-nor-false)
- nonmonotonic logics (defeasible entailment: adding premises can "remove" e.)

Cont'd

3



Semantic Presupposition Problems

Problem 1 Presupposition failure (= the p. is false in context)

- (1) Der König von Frankreich hat eine Glatze.
When uttered on May 13 2005, the presupposition is false

Problem 2 Presupposition cancellation (= the p. is "removed" in context)

- (2) Ich weiß nicht, dass Bill gekommen ist.
This utterance does not presuppose that speaker knows that Bill came.
- (3) A: Peter hat es nicht geschafft, in einen Medizindiplomstudiengang aufgenommen zu werden.
B: Peter wird es also nicht bedauern, Medizin studiert zu haben.
B's utterance does not presuppose that Peter studied medicine.



Semantic Presupposition: Problems

Problem 1 Classical logic cannot handle presupposition failure.

If we use classical logic to define semantic presupposition, then we can make the following argument:

1. ϕ presupposes ψ
2. Hence by defn, $\phi \models \psi$ and $\neg\phi \not\models \psi$
3. ϕ is true or ϕ is false (bivalence)
4. ϕ is true or $\neg\phi$ is true (negation)
5. Hence ψ (the presupposition) **must always be true**

Thus, classical logic cannot capture presupposition failure;

Nor can it explain why sentences whose presuppositions are not satisfied are odd.

To remedy this, semantic theories of presuppositions use **multi-valued logics**.



Semantic Presupposition: Problems

Problem 3

Moreover, many cases of what one would want to call presupposition are **not truth-conditional effects**, and are also strongly context-dependent. Therefore, the distinction between **semantic** and **pragmatic** presupposition is untenable and has been abandoned.



Semantic Presupposition: Problems

Problem 2 Classical entailment cannot handle presupposition cancellation.

Classical entailment is **monotonic**, i.e.,

if $\phi \models \psi$ then no matter how much information γ is added to ϕ , it is necessarily the case that $\phi, \gamma \models \psi$

i.e., no matter how much information is added to the discourse, entailments remain true;

This cannot account for the cancelling of presuppositions due to information available in the context. A possible remedy is to use a **nonmonotonic logic**.



Pragmatic Theories of Presuppositions

Besides the (mostly abandoned) semantic attempts, there are two main types of theories:

- Pragmatic theories based on a static-semantics: Gazdar (1979), Karttunen (1973), Karttunen and Peters (1979)
- Pragmatic theories based on dynamic semantics: Heim (1983), Van der Sandt (1988, 1992), Beaver (1995), Geurts (1997), etc.

Pragmatic Theories Based on Static-Semantics

Karttunen (1973): Local “Filtering” approach

Plugs predicates that block off all the presuppositions of the complement sentence (e.g., *say, mention, ask, tell*)

(4) Jon says that Peter’s sons are bald.

Holes predicates that let all the presuppositions of the complement sentence become presuppositions of the matrix sentence (e.g., *know, regret, understand, be possible, perhaps, not*)

(5) Jon regrets that Peter’s sons are bald.

Filters predicates that under certain conditions cancel some of the presuppositions of the complement (e.g., *if-then, either-or, and*)

(6) If baldness is hereditary, Peter’s sons are bold.

(7) If Peter has sons, Peter’s children are bold.

Karttunen (1973)

- first formal definition of presuppositions which concerns the presuppositions of utterances rather than sentences (i.e., pragmatic)
- determines the presuppositions of a complex sentence as a subset of the potential presuppositions of the components
- bottom-up
- progressive adding of propositions also at sub-sentence level
- makes use of: semantic content, presupposition content, heritage expression
- **“Filtering” approach** to presupposition projection

Karttunen (1973): Local “Filtering” approach

Local Filtering:

Given a function π which maps simple sentences or complex constructions onto sets of potential presuppositions:

1. $P(S) = \pi(S)$ for simple sentences S
2. $P(S') = P(S) \cup \pi(S')$ where S' embeds S by a hole
3. $P(S') = \pi(S')$ where S' embeds S by a plug
4. If S is “If A then B” or “A and B”:

$$P(S) = P(A) \cup \langle p \in P(B) \mid (\mathbf{F} \cup \{A\}) \not\models p \rangle$$
5. If S is “Either A or B”:

$$P(S) = P(A) \cup \langle p \in P(B) \mid (\mathbf{F} \cup \{\neg A\}) \not\models p \rangle$$

Gazdar (1979): Global Cancellation Approach

- like Karttunen, proposes a context-sensitive model
- like Karttunen, determines the presuppositions of a complex sentence as a subset of the potential presuppositions of the components
- unlike Karttunen, not bottom-up
- unlike Karttunen, progressive adding of propositions only at text level, not below sentence

Gazdar (1979): Global Cancellation Approach

All potential presuppositions of component sentences are collected into a set, and then from that set are removed those which are in conflict with:

1. propositions in the previous context
2. entailments of the utterance
3. the implicatures associated with the utterance
4. each other

Satisfiable incrementation of a context set X with a set of propositions Y : the original set plus those propositions in Y which cannot introduce inconsistency.

A problem with both Filtration and Cancellation

Pragmatic information may enter into binding relations with the content expression.

- (8) A child likes his cat.
 Ein Kind liebt seine Katze
- a. $\exists x \exists y (Child(x) \wedge Cat(y) \wedge like(x, y))$ (Content)
 - b. $\exists x \exists y (Child(x) \wedge Cat(y) \wedge poss(x, y))$ (Presup.)

Predicted Meaning: There is a child who likes his cat and there is a (possibly different) child who has a cat.

Intended Meaning: There is a child who has a cat and who likes it.

Pragmatic Theories Based on Dynamic-Semantics

Dynamic Semantics Approaches to Presupposition

Basic idea of dynamic semantics (Strawson, Karttunen, Heim): sentences are uttered by speakers to change the context; i.e., the meaning of a sentence is its context-change potential.

Basic idea of dynamic-semantic approach to presupposition projection from Karttunen (1974):

“Instead of characterizing contexts by compiling the presuppositions of the sentence, we ask what a context would have to be like in order to satisfy those presuppositions.”

Satisfaction model:

Context X **admits** S just in case the presuppositions of each of the constituent sentences in S are satisfied by the corresponding local context.

Discourse Representation Theory

- Kamp's Discourse Representation Theory (DRT) is a theory developed to deal with the interpretation of inter- and intra-sentential anaphora.
- DRT's semantic representation language (i.e. syntax) is the language of DRSs i.e. DR Structures
- The semantics of DRSs is formulated in terms of embeddings in a first-order model.
- There is a direct translation procedure to translate DRSs into first-order formulae

Dynamic Semantics

- Strawson: meanings of utterances as **context update functions**
- Karttunen (1976): **discourse referents** –discourse context updating amounts to incrementally adding information, i.e., adding new discourse referents and/or adding conditions on and relations between discourse referents
- Heim (1982, 1983): File Change Semantics. “File-card” metaphor of discourse referent management.
- Kamp (1981): Discourse Representation theory .
Kamp's approach shares basic intuitions with Heim's, and is also technically very similar. Nowadays an accepted standard.
- Groenendijk and Stokhof (1991): Update Semantics. Evolved from dynamic predicate logic.

Discourse Representation in DRT

(9) Jo has a cat.

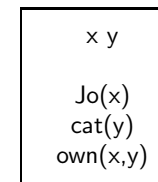

(10) Jo has a black cat.

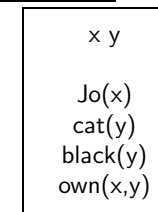

Context Update and “Binding” in DRT

(11) (a) Jo has a cat. (b) It is black

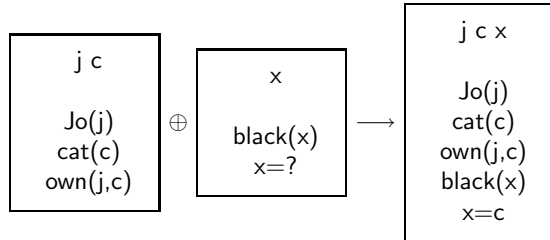

Presupposition Handling in Dynamic Semantics Based on van der Sandt’s Approach

Dynamic Semantics Approaches to Presupposition

- Stalnaker 1973-4: presuppositions are never canceled; if they sometimes seem to vanish it is because they may be satisfied by a local context
- Karttunen 1974: satisfaction model
- Heim (1982, 1983): Heim elaborates Karttunen’s satisfaction model in her File Change Semantics approach; further follow up, e.g., Beaver, Krahmer.
- Kamp (1981): In DRT, van der Sandt proposes a model of presuppositions as anaphors, nowadays accepted as standard. Further follow up, e.g., Geurts.
- Groenendijk and Stokhof (1991): Update Semantics. Evolved from dynamic predicate logic. Further follow up. e.g., Veltman, Hendriks, Dekker, Beaver.

Presuppositions as Anaphors (van der Sandt 1989, 1992)

Basic observation: **Presuppositions are like anaphors:**

- (12) Jo’s cat is black.
 >> Jo has a cat.
- (13) Jo has a cat and *Jo’s cat is black*.
- (14) If Jo has a cat, then *Jo’s cat is black*.
- (15) Either Jo has no cat or *Jo’s cat is black*.

(13-15) do not presuppose that Jo has a cat.

Note that if we replace the presuppositional trigger *Jo’s cat* with the pronoun *it*, we get semantically equivalent sentences.

Presuppositions as Anaphors

- So, instead of saying that the presupposition is filtered or cancelled or suspended, van der Sandt claims that like any other kind of anaphors, presuppositions can be
 - **bound** to an antecedent (this explains filtering)
 - **accommodated** (this explains survival)
- Based on DRT account of anaphora: a presupposition introduces an anaphoric DRS which needs to be resolved
- Presuppositions are special types of anaphors
- Presuppositions differ from pronominal anaphors in that
 - They have internal structure and thus may contain anaphors which may be bound by external quantifiers
 - They have descriptive content which permits **accommodation** (i.e. adding an appropriate antecedent to the context if need be)

How are presuppositional anaphors resolved?

- Resolution works **up the accessibility path** and binding to the nearest antecedent is preferred. If the p-anaphor cannot be resolved and thus must be accommodated, accommodation goes **down the accessibility path** and accommodation to the highest site is preferred.
- If the p-anaphor can be resolved to some **accessible antecedent**, the conditions associated with the presuppositional anaphor are transferred to the antecedent site and the anaphoric marker identified with its antecedent marker.
- If the p-anaphor is accommodated and the corresponding semantic material transferred to the **accommodation site**.

If p-anaphors are embedded within one another the deepest is resolved first, then the next deepest etc.

- (16) *Mary did not realise that it was Harry who bought the butcher's goose*
- » The butcher has a goose
 - » Someone bought it (=the butcher's goose)
 - » Harry did (=bought the butcher's goose)

Presupposition Handling in Dynamic Semantics Based on van der Sandt's Approach

Examples

Presupposition Checking during Context Update

A presupposition can be satisfied by “binding” to a suitable antecedent:

- (17) (a) Jo has a cat. (b) Jo’s cat is black.

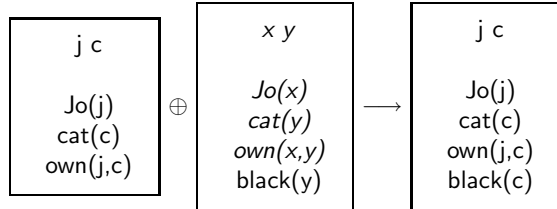

(Note: presupposed material is typed in italics)

Presupposition Checking during Context Update

A presupposition can fail due to incompatible material present in context:

- (18) (a) Jo has no cat. (b) Jo’s cat is black.

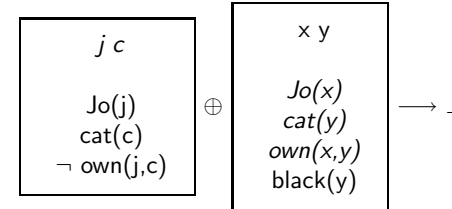

Presupposition Checking during Context Update

A presupposition can be added when no incompatible material present in context (presupposition accommodation):

- (19) (a) Jo has a house. (b) Jo’s cat is black.

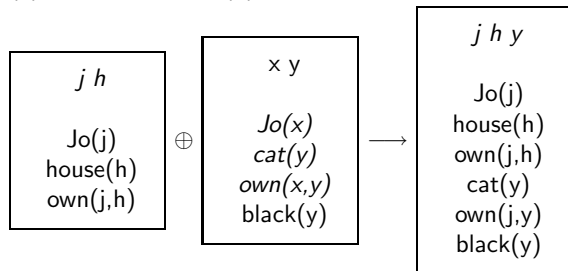

Presupposition Checking during Context Update

- (20) If Jo has a cat, Jo’s cat is black.

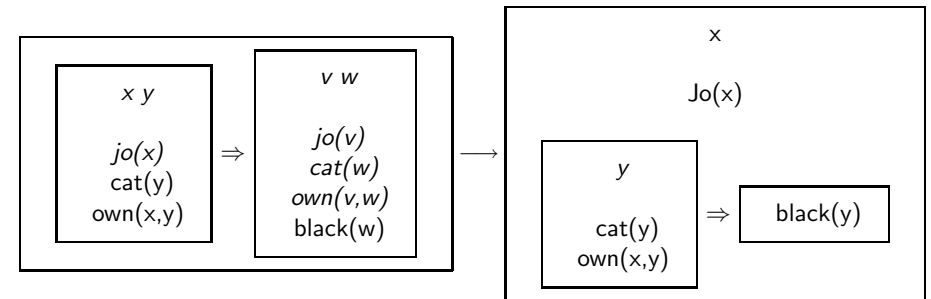

Presupposition Checking during Context Update

(21) If Jo has a house, Jo's cat is black.

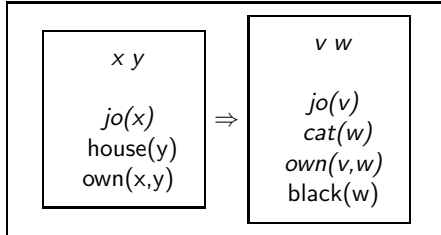

The theory predicts an ambiguity due to different possibilities for presupposition accommodation.

Presupposition Accommodation Ambiguity

(22) If Jo has a house, Jo's cat is black.

Can be interpreted as:

- Jo exists. Jo has a cat. If Jo has a house, Jo's cat is black.
- Jo exists. If Jo has a house and a cat, Jo's cat is black.
- Jo exists. If Jo has a house, then Jo has a cat and Jo's cat is black.

(a)

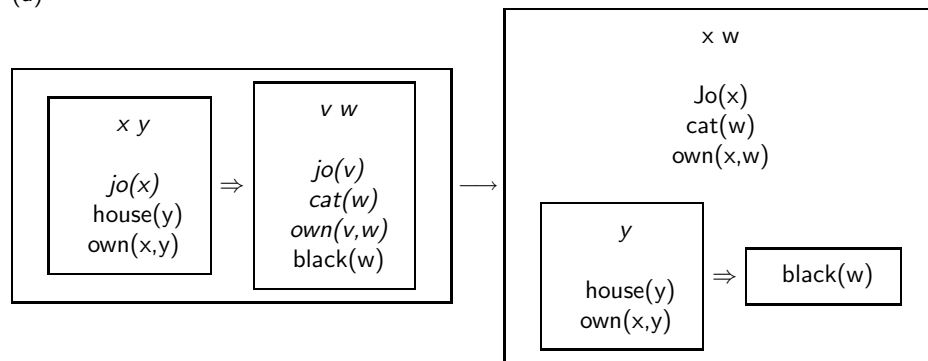

(b)

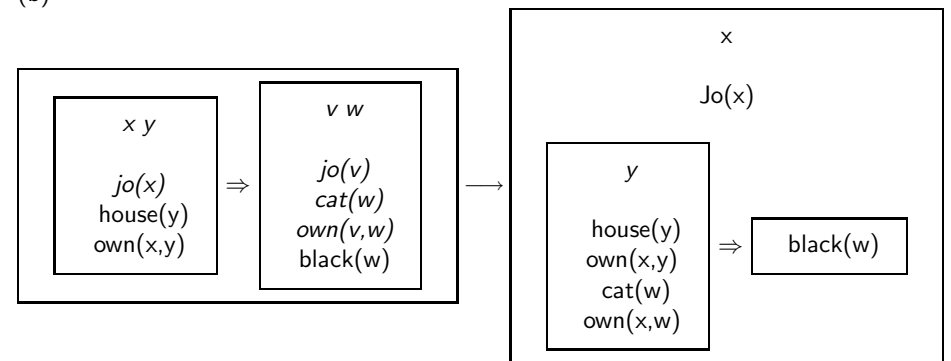

(c)

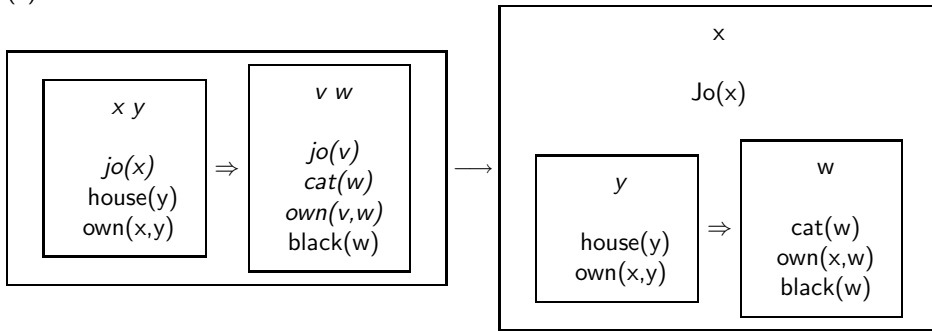

Pragmatic constraints of presupposition resolution

The resulting proper DRS must obey some formal (no free variable) and pragmatic constraints

- **informativity**
- **consistency**

Pragmatic constraints of presupposition resolution

(23) Either the king or the president of France opened the show.

Consistency: Assuming that countries cannot have both a king and a president, accommodation of both a king and a president would violate consistency (the resulting interpretation is inconsistent with WKL).

Local Consistency: Accommodating just one of the presuppositions would violate local consistency: *France has a unique King and either this King or the unique president of France opened the show*

Local Informativity:

(24) If John is married, his wife is happy.

Does not have the presupposing reading *John has a wife and if John is married, his wife is happy*, because this would make the condition uninformative, since *John has a wife* entails *John is married*.

Alternative analysis: Marriage entails having a wife. Entailment should block accommodation at any higher site. (cf. also bridging anaphora: inferred antecedents).

(25) John loves scuba diving. His regulator was really expensive.

(26) If John goes scuba diving, he takes his regulator.

Ambiguous presuppositional expressions

(27) If John has sons, his children are happy.

Allows both binding and accommodation.

Binding: If John has sons, they are happy.

Accommodation: John has children and if John has sons, his children are happy.

Ambiguous Presuppositional Expressions

(29) If John has an oriental girlfriend, his girlfriend won't be happy.

Accommodation: “presupposing reading” (the presupposition/anaphor is not resolved (bound) to “an oriental girlfriend”):

John has a girlfriend and if John has an oriental girlfriend, his girlfriend won't be happy.

Binding: “non-presupposing reading” (the presupposition/anaphor is resolved (bound) to “an oriental girlfriend”):

If John has an oriental girlfriend, she won't be happy.

Ambiguous presuppositional expressions

(28) If John has grandchildren, his children are happy.

Allows two types of accommodation with one preferred reading (i.e. top level accommodation).

Preferred reading: John has children and if John has grandchildren, his children are happy.

Second possible reading: if John has grandchildren and thus children, his children are happy.

Summary

What are Presuppositions:

- Frege: special conditions that must be met in order for a linguistic expression to have a denotation.
- Semantic theories: binary relations between sentences, defined either in terms of semantic valuation (i.e., Strawson: ϕ presupposes ψ iff the truth of ψ is a condition for a semantic value of ϕ to be True or False) or in terms of semantic entailment (i.e., ϕ presupposes ψ iff $\phi \models \psi$ and $\neg\phi \not\models \psi$).
- Pragmatic theories: not just relations between sentences
 - conditions that a context must obey for an utterance of a sentence to be felicitous

Summary: Problems with Frege's Theory

Problem 1: Presuppositional expressions need not refer.

Example: "Every man kissed the woman who loved him"

v.d. Sandt: Presuppositional expressions are anaphors (and thus need not refer)

Problem 2: A sentence can have a meaning even if its presupposition is false.

Examples: "Either Jon does not have children or his children are on holiday",
"The King of France is not bald because there is no King of France".

v.d. Sandt: Either the presupposition is bound and the sentence meaning independent of the presupposition itself or the presupposition is accommodated and pragmatic constraints constrains accommodation so that the resulting reading makes sense.

Summary: Problems with other theories

Problems with Semantic Theories

Cannot account for presupposition defeasibility.

v.d. Sandt: Defeasibility is captured through binding or accommodation to a sub-level of the DRS.

Problems with Static Pragmatic Theories

Semantic and presuppositional information are represented separately which yields wrong predictions concerning the communicated meaning.

v.d. Sandt: Semantic and presuppositional information are represented in a uniform way. Problem does not occur.