

Grammatikformalismen

Lecture 26.06.2012

PD Dr.Valia Kordoni

Email: kordoni@coli.uni-sb.de

<http://www.coli.uni-saarland.de/courses/grammatikformalismen/2012/>

Head-Driven Phrase Structure Grammar (HPSG)

Introduction – Part V -

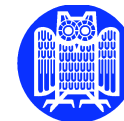

ID Schemas

We have already seen two ID rules:

- Head-Complement Rule

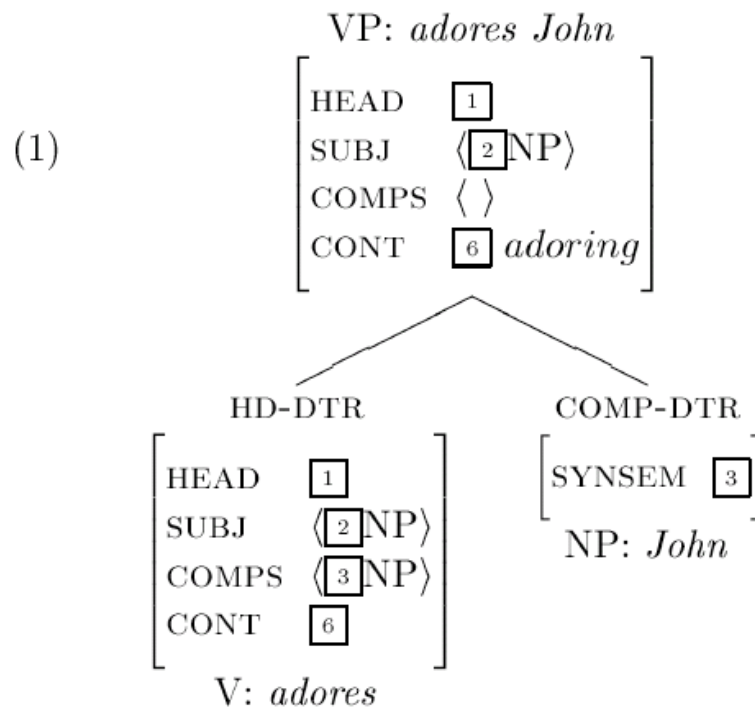

ID Schemas (cont.)

- Head-Subject Rule

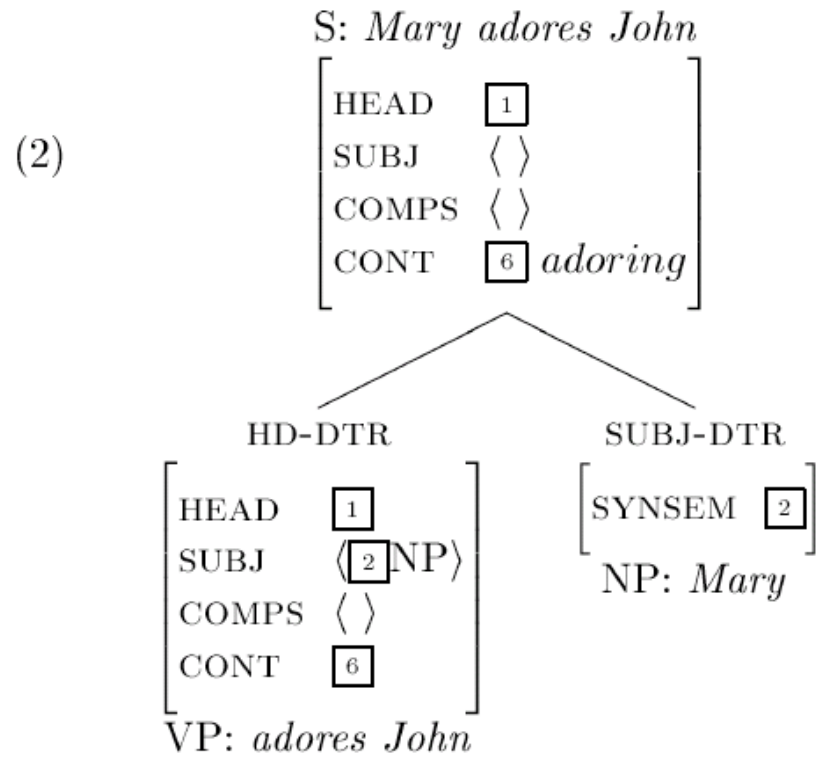

ID Schemas (cont.)

Here we introduce three more ID schemas:

- Head-Adjunct Rule: for combining heads with modifiers such as adjectives and adverbs
- Head-Specifier Rule: for combining nouns with determiners and possessives, prepositions with degree adverbials
- Head-Marker Rule: for combining VP heads with complementizers

And three more principles:

- SPEC Principle (SpecP)
- Quantifier Inheritance Principle (QIP)
- MARKING Principle (MarkP)

Head-Adjunct Schema

Lexical entry for the adjective (\bar{N} modifier) *black*:

(3)

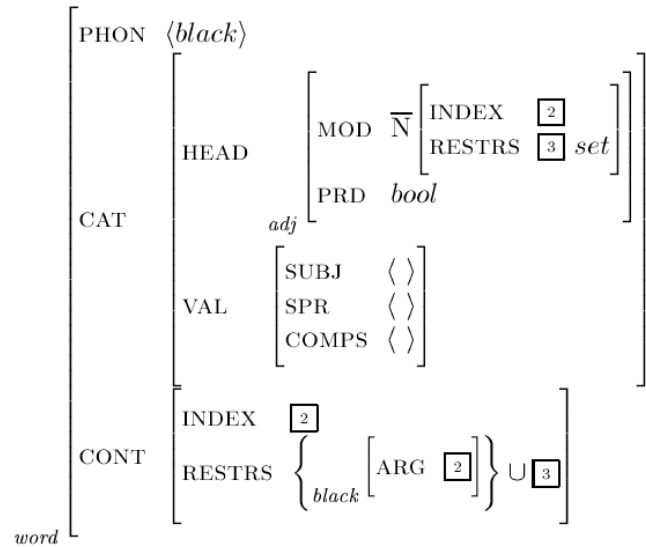

where \bar{N} is an abbreviation for

(4)

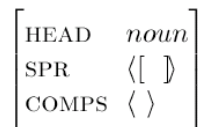

The rule

The basic ID rule: a phrase with a DTRS value of type *head-adjunct-structure* where the head daughter's SYNSEM value is token identical to the adjunct daughter's MOD value.

(5)

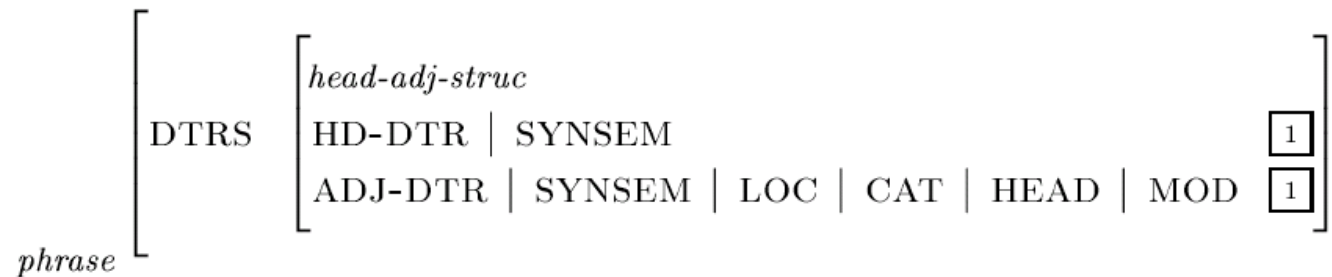

The rule (cont.)

Expanded via the HFP, ValP, SemP:

(6)

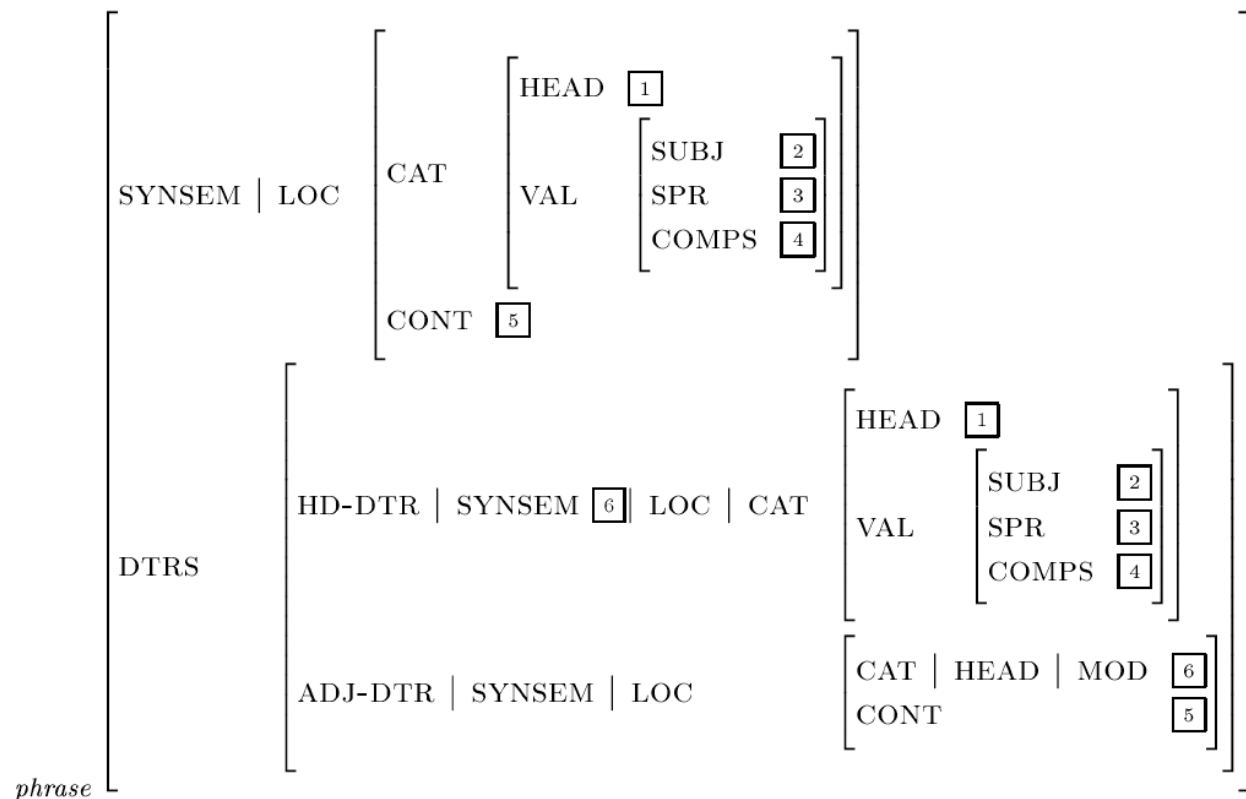

The rule (cont.)

Notes:

- HFP operates as usual, since this is a headed phrase.
- No valency requirements are discharged; the head daughter's valence lists are passed on to the phrase unchanged.
- The adjunct daughter is the semantic head, so the phrase shares its CONTENT value.

An example

Structure for the \bar{N} *black coffee*:

(7)

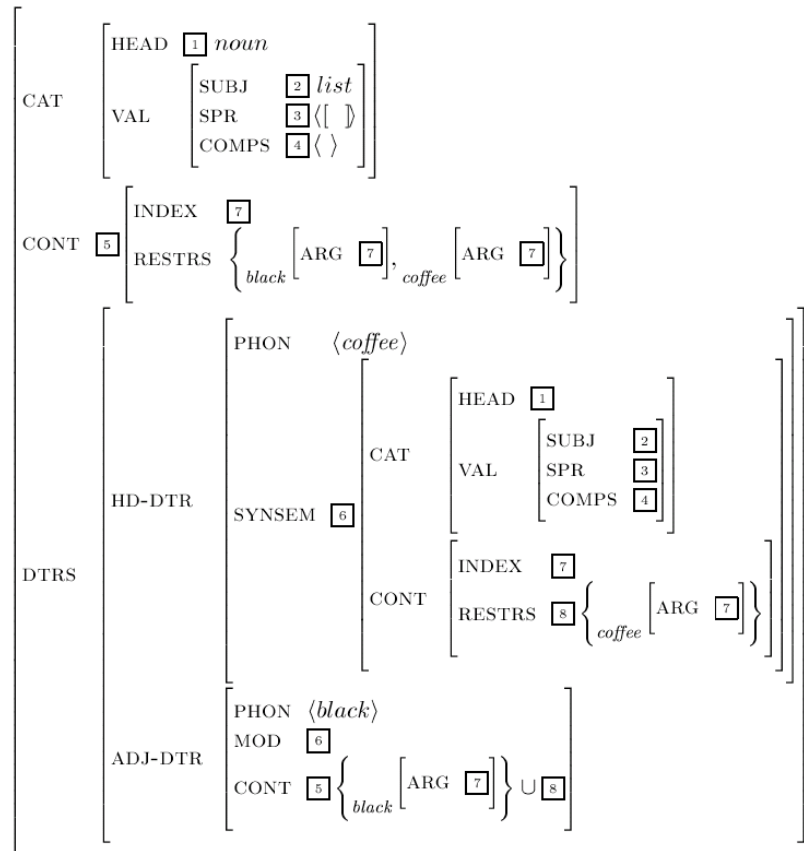

An example (cont.)

As a tree:

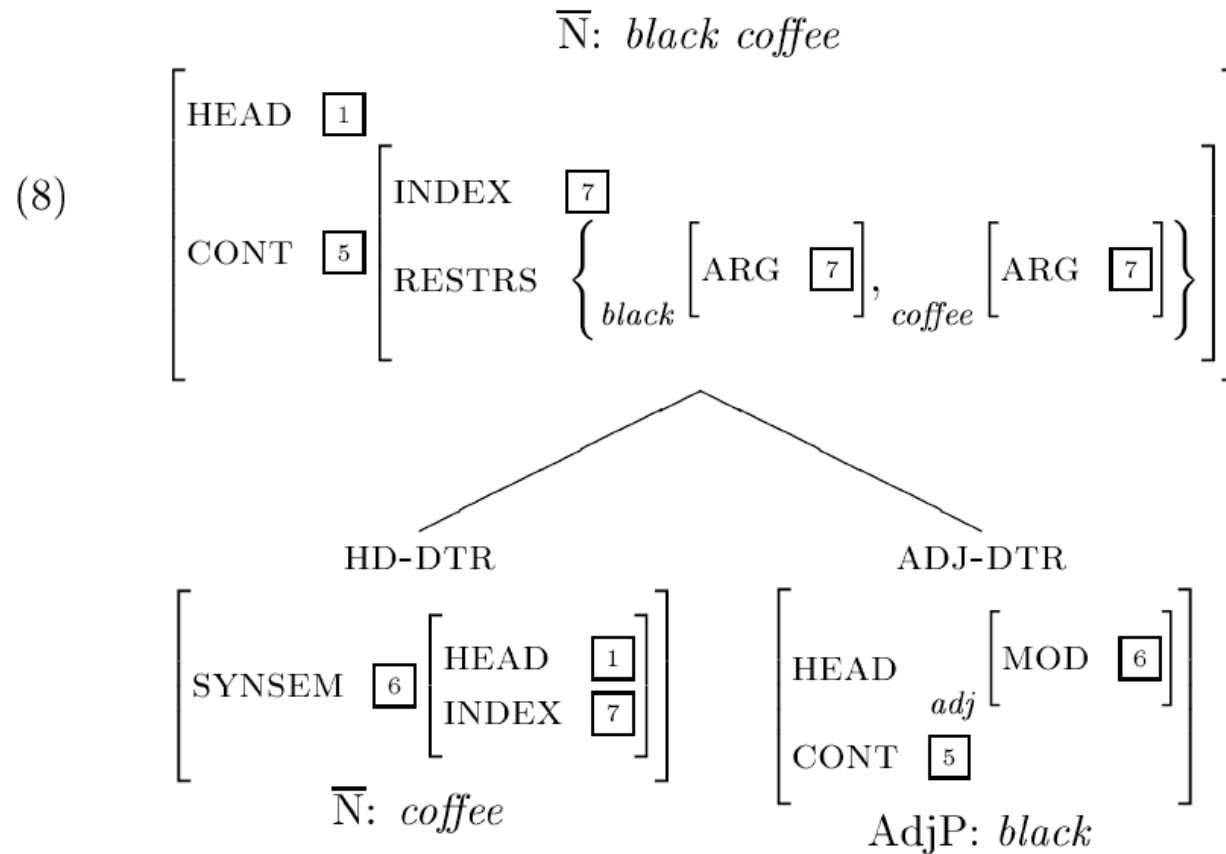

Head-Specifier Schema

Lexical entry for the determiner *the*:

(9)

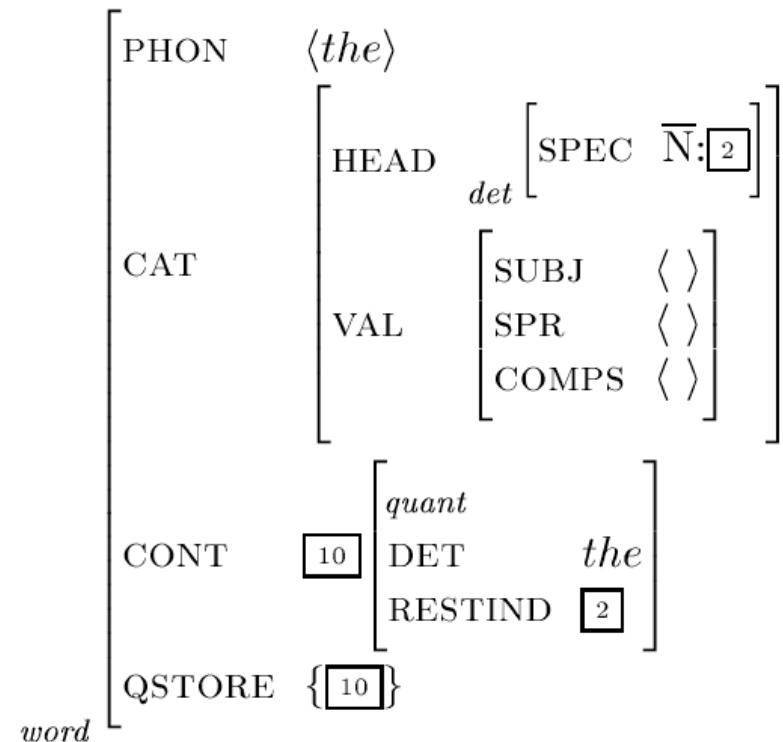

The rule

The basic ID rule: a phrase with a DTRS value of type *head-specifier-structure*.

(10)

$$\textit{phrase} \left[\begin{array}{l} \text{DTRS} \left[\begin{array}{l} \textit{head-spr-struct} \\ \text{HD-DTR} \quad \textit{sign} \\ \text{SPR-DTR} \quad \langle \textit{sign} \rangle \end{array} \right] \end{array} \right]$$

Expanded via

- HFP: as expected
- ValP: one item cancelled from head daughter's SPR list
- SemP: The head daughter is the semantic head.

The rule (cont.)

(11)

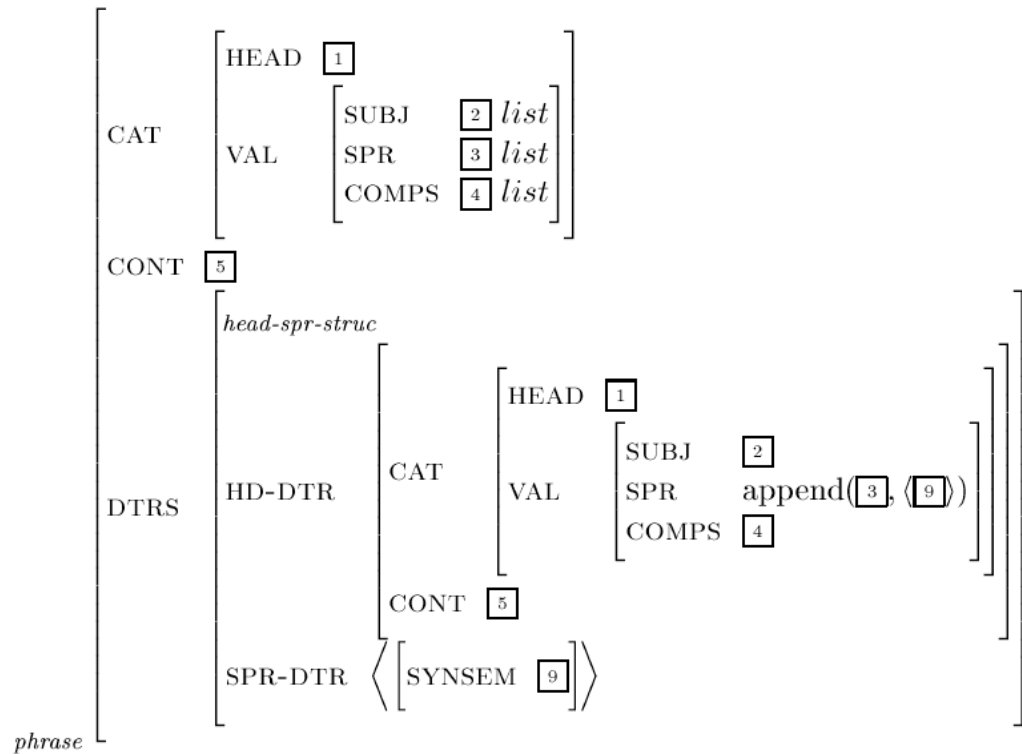

Two new principles are needed for head-specifier phrases, but first we will add in the relevant lexical entries.

Example

Structure for the NP *the black coffee* (first version):

(12)

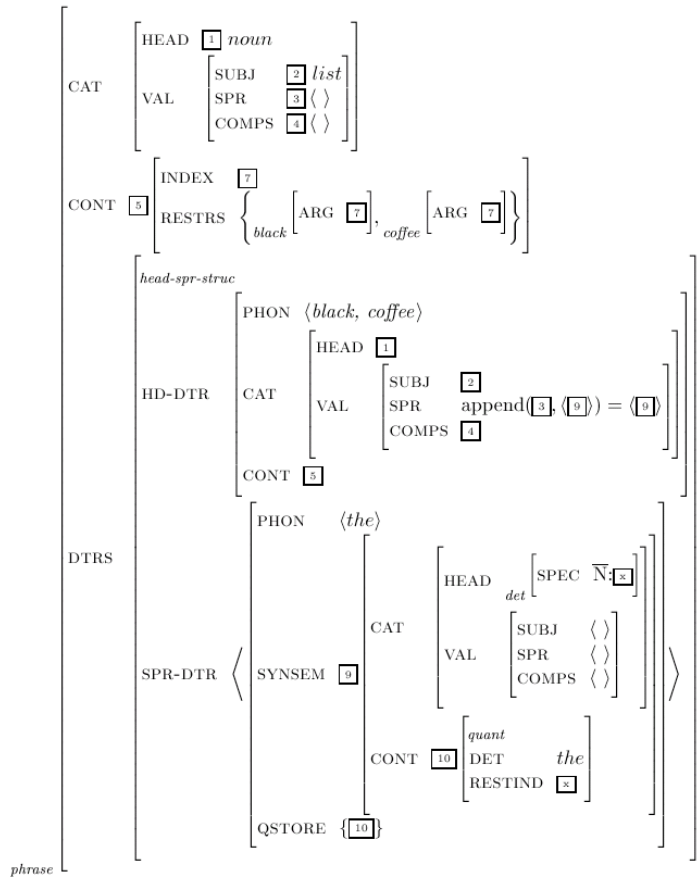

Two problems:

- Nothing ensures the structure sharing of the determiner's RESTIND value and the CONTENT of the \bar{N} . I.e., we need a principle to specify that $x = 5$.
- The semantic content of the quantifier is not present at the phrasal level.

Example (cont.)

Two new principles:

- SPEC Principle:

The SYNSEM | LOC | CAT | HEAD | SPEC value of the non-head daughter (if it has one) is token identical to the SYNSEM value of the head daughter.

(13)

$$\left[\begin{array}{l} \text{HD-DTR} \mid \text{SYNSEM} \quad \boxed{1} \\ \text{"NON-HD-DTR"} \mid \text{SYNSEM} \mid \text{LOC} \mid \text{CAT} \mid \text{HEAD} \mid \text{SPEC} \quad \boxed{1} \end{array} \right]$$

Note that this principle, in combination with the Valence Principle, introduces a cycle in the feature structure for head-specifier phrases.

- Quantifier Inheritance Principle (simplified):

The QSTORE value of a phrase is the union of the QSTORE values of its daughters.

(14)

$$\left[\begin{array}{l} \text{DTRS} \quad \left[\begin{array}{l} \text{HD-DTR} \mid \text{QSTORE} \quad \boxed{1} \\ \text{"NON-HD-DTRS"} \quad \langle \text{QSTORE} \quad \boxed{2}, \text{QSTORE} \quad \boxed{3}, \dots \rangle \end{array} \right] \\ \text{QSTORE} \quad \cup(\boxed{1}, \boxed{2}, \boxed{3}, \dots) \end{array} \right]_{\text{phrase}}$$

Example (cont.)

With these two principles in place, the structure of the NP is

(15)

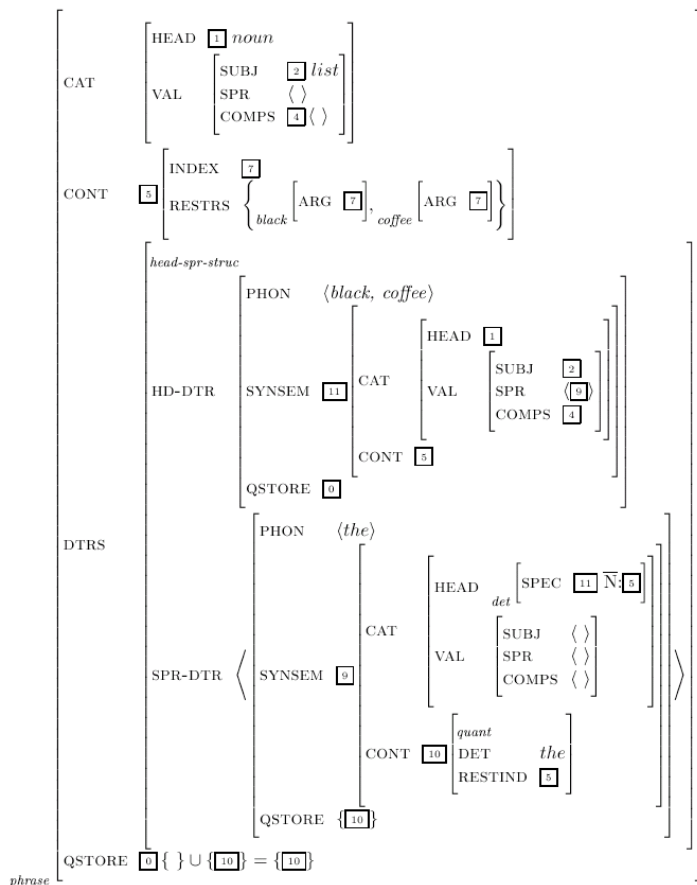

As a tree:

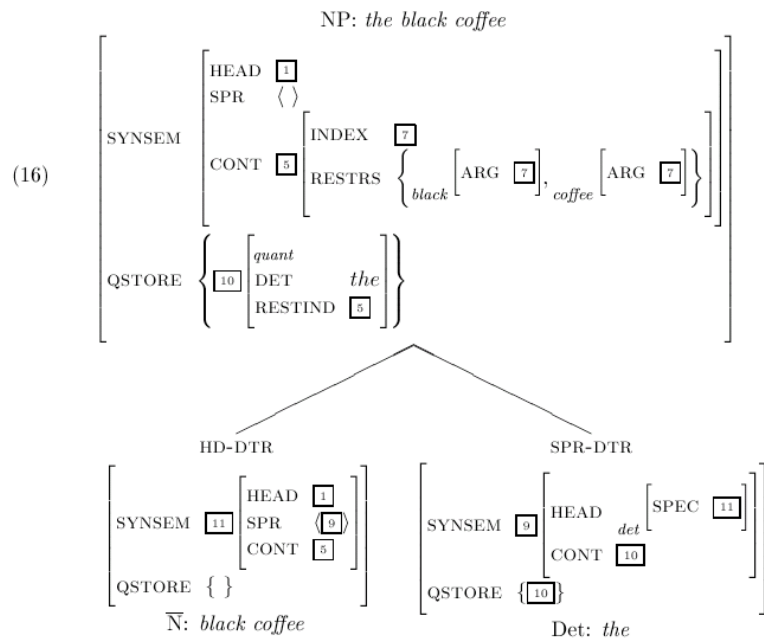

Head-Marker Schema

Lexical entry for *if*:

(17)

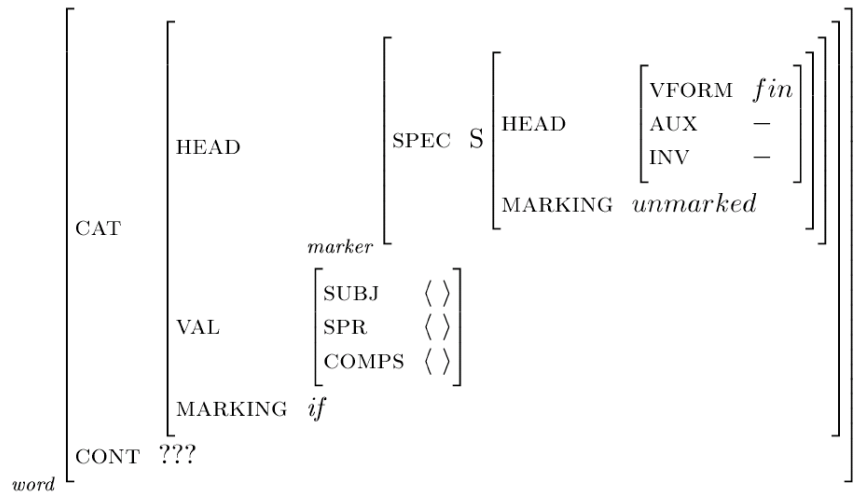

where S is an abbreviation for

(18)

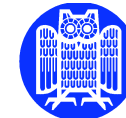
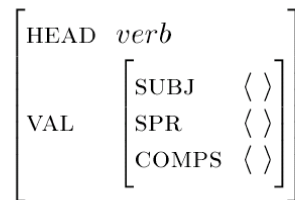

The rule

Minimally: a phrase with a DTRS value of type *head-marker-structure* whose marker daughter is a marker.

(19)

$$\textit{phrase} \left[\text{DTRS} \left[\begin{array}{l} \textit{head-mark-struct} \\ \text{HD-DTR} \\ \text{MARK-DTR} \mid \text{SYNSEM} \mid \text{LOC} \mid \text{CAT} \mid \text{HEAD} \end{array} \begin{array}{l} \\ \\ \textit{sign} \\ \textit{marker} \end{array} \right] \right]$$

The rule (cont.)

Plus the three principles HFP, ValP, SemP:

(20)

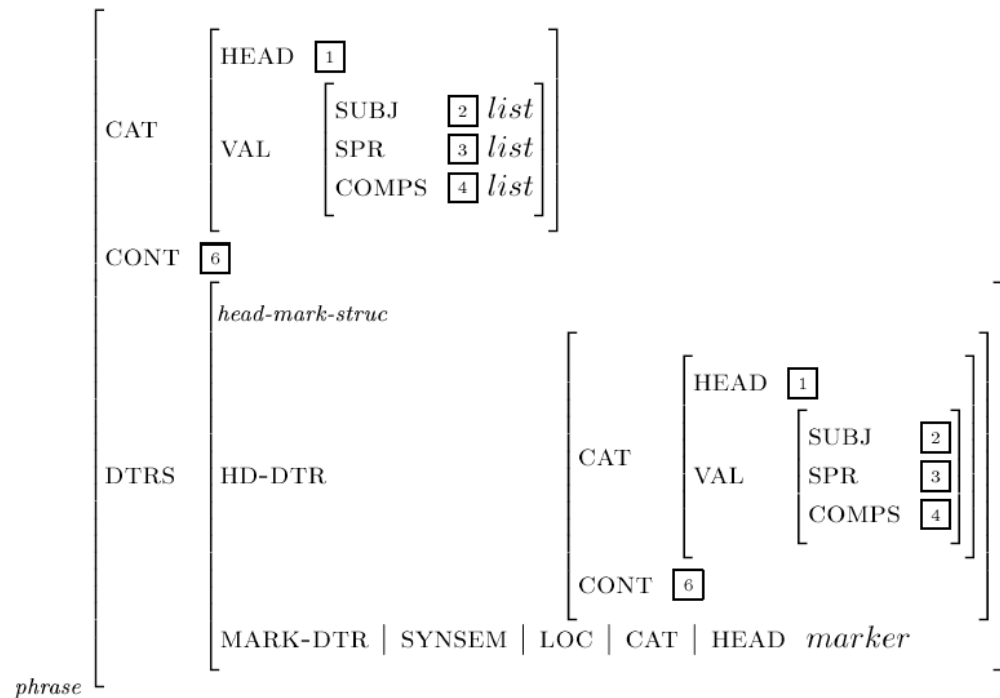

We need to add in the SPEC Principle and a new principle (the MARKING Principle), but first we will introduce the lexical entries.

An example

The structure for the \bar{S} *if Mary adores John*, as in the following sentence:

- (21) I wonder [if Mary adores John].
- (22) \bar{S} , first version:

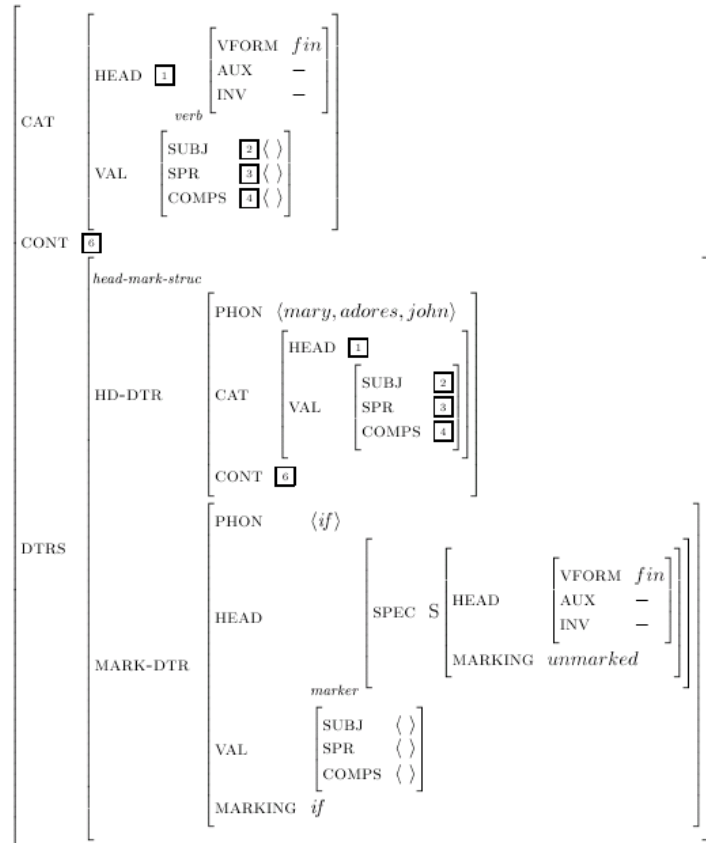

SpecP ensures that the head daughter's SYNSEM matches the marker daughter's SPEC value. So far, the phrase has no MARKING specification. We need the MARKING Principle:

In a head-marker structure, the MARKING value is token identical to the marker daughter's MARKING value.

- (23)



Otherwise, the MARKING value is token identical to the head daughter's MARKING value.

An example (cont.)

The \bar{S} structure in (22) plus SpecP and MarkP:

(24)

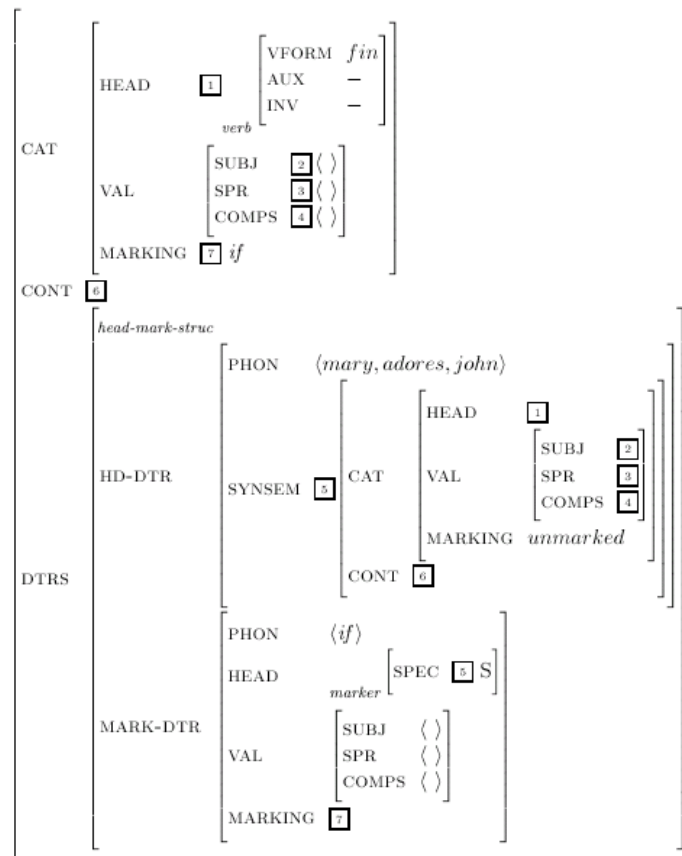

Tree notation:

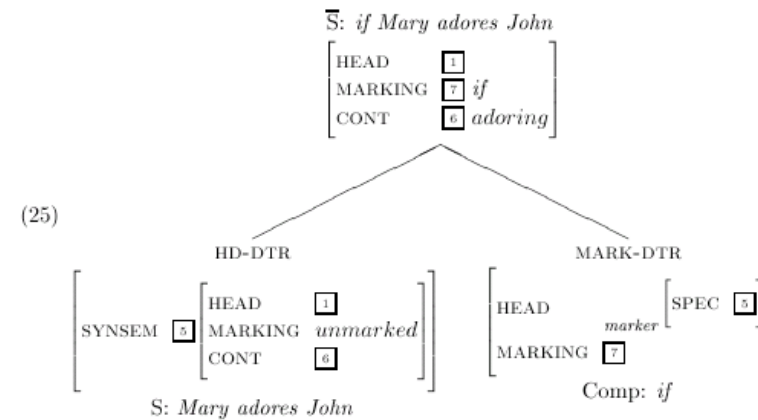

Summary of ID rules and principles

The ID schemas and principles can be seen as constraints on types. Negation and disjunction are allowed (and therefore conditional constraints are also possible).

We assume that the type *phrase* subsumes two subtypes *headed-phrase* and *non-headed-phrase*, following Sag (1997). They are defined as follows:

(26) a.

$$hd-ph \left[\begin{array}{l} \text{DTRS } head-struct \end{array} \right]$$

b.

$$hd-ph \left[\begin{array}{l} \text{DTRS } \neg head-struct \end{array} \right]$$

Summary of ID rules and principles (cont.)

Four of the principles we have seen so far can be expressed as constraints on *headed-phrase*:¹

(27) Head Feature Principle

$$hd-ph \left[\begin{array}{l} \text{SYNSEM} \mid \text{LOC} \mid \text{CAT} \mid \text{HEAD} \\ \text{DTRS} \mid \text{HD-DTR} \mid \text{SYNSEM} \mid \text{LOC} \mid \text{CAT} \mid \text{HEAD} \end{array} \begin{array}{l} \boxed{1} \\ \boxed{1} \end{array} \right]$$

¹Strictly speaking, MarkP is a constraint on *phrase* but we will restrict our attention to headed phrases. In fact, all of the principles can be expressed as constraints on *phrase* with the addition of a disjunctive clause for *non-hd-ph*.

Summary of ID rules and principles (cont.)

(29) Semantics Principle

$$\begin{array}{l}
 \left[\begin{array}{l} \text{SYNSEM} \mid \text{LOC} \mid \text{CONT} \quad \boxed{1} \\ \text{DTRS} \left[\begin{array}{l} \textit{head-adj-struct} \\ \text{ADJ-DTR} \mid \text{SYNSEM} \mid \text{LOC} \mid \text{CONT} \quad \boxed{1} \end{array} \right] \end{array} \right] \vee \\
 \textit{hd-ph} \\
 \left[\begin{array}{l} \text{SYNSEM} \mid \text{LOC} \mid \text{CONT} \quad \boxed{1} \\ \text{DTRS} \left[\begin{array}{l} \textit{head-struct} \wedge \neg \textit{head-adj-struct} \\ \text{HD-DTR} \mid \text{SYNSEM} \mid \text{LOC} \mid \text{CONT} \quad \boxed{1} \end{array} \right] \end{array} \right] \\
 \textit{hd-ph}
 \end{array}$$

Summary of ID rules and principles (cont.)

(30) MARKING Principle

$$\begin{array}{l}
 \left[\begin{array}{l} \text{SYNSEM} \mid \text{LOC} \mid \text{CAT} \mid \text{MARKING} \boxed{1} \\ \text{DTRS} \left[\begin{array}{l} \textit{head-mark-struct} \\ \text{MARK-DTR} \mid \text{SYNSEM} \mid \text{LOC} \mid \text{CAT} \mid \text{MARKING} \boxed{1} \end{array} \right] \end{array} \right] \vee \\
 \textit{hd-ph}
 \end{array}$$

$$\begin{array}{l}
 \left[\begin{array}{l} \text{SYNSEM} \mid \text{LOC} \mid \text{CAT} \mid \text{MARKING} \boxed{1} \\ \text{DTRS} \left[\begin{array}{l} \textit{head-struct} \wedge \neg \textit{head-mark-struct} \\ \text{HD-DTR} \mid \text{SYNSEM} \mid \text{LOC} \mid \text{CAT} \mid \text{MARKING} \boxed{1} \end{array} \right] \end{array} \right] \\
 \textit{hd-ph}
 \end{array}$$

SpecP and the five ID schemas we have seen are constraints on subsorts of *constituent-structure* (the type of the DTRS attribute). Note that until now we have described the ID rules as constraints on entire phrasal signs, but in fact they only refer to the DTRS value.

Summary of ID rules and principles (cont.)

(31) SPEC Principle

$$\begin{array}{l}
 \text{head-spr-struct} \left[\begin{array}{l} \text{HD-DTR} \mid \text{SYNSEM} \\ \text{SPR-DTR} \mid \text{SYNSEM} \mid \text{LOC} \mid \text{CAT} \mid \text{HEAD} \mid \text{SPEC} \end{array} \begin{array}{l} \boxed{1} \\ \boxed{1} \end{array} \right] \vee \\
 \text{head-mark-struct} \left[\begin{array}{l} \text{HD-DTR} \mid \text{SYNSEM} \\ \text{MARK-DTR} \mid \text{SYNSEM} \mid \text{LOC} \mid \text{CAT} \mid \text{HEAD} \mid \text{SPEC} \end{array} \begin{array}{l} \boxed{1} \\ \boxed{1} \end{array} \right]
 \end{array}$$

(32) Head-Complement Schema

$$\text{head-comp-struct} \left[\begin{array}{l} \text{HD-DTR} \quad \textit{sign} \\ \text{COMP-DTRS} \quad \textit{list}(\textit{sign}) \end{array} \right]$$

(33) Head-Subject Schema

$$\text{head-subj-struct} \left[\begin{array}{l} \text{HD-DTR} \mid \text{SYNSEM} \mid \text{LOC} \mid \text{CAT} \mid \text{VAL} \mid \text{COMPS} \langle \rangle \\ \text{SUBJ-DTR} \quad \langle \textit{sign} \rangle \end{array} \right]$$

Summary of ID rules and principles (cont.)

(34) Head-Adjunct Schema

$$\text{head-adj-struct} \left[\begin{array}{l} \text{HD-DTR} \mid \text{SYNSEM} \\ \text{ADJ-DTR} \mid \text{SYNSEM} \mid \text{LOC} \mid \text{CAT} \mid \text{HEAD} \mid \text{MOD} \end{array} \begin{array}{l} \boxed{1} \\ \boxed{1} \end{array} \right]$$

(35) Head-Specifier Schema

$$\text{head-spr-struct} \left[\begin{array}{l} \text{HD-DTR} \quad \textit{sign} \\ \text{SPR-DTR} \quad \langle \textit{sign} \rangle \end{array} \right]$$

(36) Head-Marker Schema

$$\text{head-mark-struct} \left[\begin{array}{l} \text{HD-DTR} \quad \textit{sign} \\ \text{MARK-DTR} \mid \text{SYNSEM} \mid \text{LOC} \mid \text{CAT} \mid \text{HEAD} \quad \textit{marker} \end{array} \right]$$

The five schemas (plus two others we have not seen yet) are in fact the disjunctive clauses of a general principle (the **Immediate Dominance Principle**) that constrains the constituent structure of all phrases.

Note: We will ignore the QIP.

References

Sag, I. A. (1997). English relative clause constructions. *Journal of Linguistics*, 33, 431–484.