

**Proceedings of FGVienna: The
8th conference on Formal
Grammar**

**G. Jaeger, P. Monachesi, G. Penn
and S. Wintner (eds.)**

November 15, 2003

**CENTER FOR THE STUDY
OF LANGUAGE
AND INFORMATION**

Contents

1	An Asymmetric Theory of Peripheral Sharing in HPSG	1
	BERTHOLD CRYSMANN	

An Asymmetric Theory of Peripheral Sharing in HPSG: Conjunction Reduction and Coordination of Unlikes

BERTHOLD CRYSMANN

In this paper, I will address the phenomenon of Conjunction Reduction and suggest a linearisation-based account that differentiates between heads and dependents as to the strength of the identity requirements they observe in constructions displaying peripheral sharing. This distinction will build the foundation of an asymmetric surface-oriented theory of reconstruction that will be able to avoid unwanted unification clashes on the valence lists of heads, obviating the need for subsumption checks and/or generalisation operations in HPSG. I will further show that this theory of Conjunction Reduction can also be applied to resolve similar issues associated with Coordination of Unlikes, resulting in a much more stream-lined, purely unification-based perspective on coordination in HPSG.

1.1 Introduction

The area of coordination has always been a challenge for unification-based phrase structure grammar as soon as the scope of data to be addressed was extended beyond simple constituent coordination. While on the one hand, unification was claimed to be too strong a concept to implement the kind of likeness conditions that appear operative in cases of feature indeterminacy and Coordination of Unlikes (Ingria, 1990, Bayer and Johnson, 1995, Bayer, 1996), orientation towards classical constituent structure does not seem to provide the right tools to address instances of Non-Constituent Coordination (NCC), such as Conjunction Reduction (CR; see (1)) or Right-Node Raising (RNR; see (2)).

- (1) Bill gave the girls spades and the boys recorders. (Maxwell and Manning, 1996)

- (2) Bill likes, and Joe is thought to like cigars from Cuba. (Maxwell and Manning, 1996)

Despite differences in implementation, the solutions that researchers within the frameworks of LFG or HPSG have come-up with display a high degree of similarity. Whereas feature indeterminacy is addressed by means of a refinement to the representation of morphosyntactic features, either as sets (Dalrymple and Kaplan, 2000) or type hierarchies (e.g. Daniels, 2001),¹ NCC is resolved by appeal to surface order, using suspension/resumption of c-structure rules (Maxwell and Manning, 1996), or by applying extended word order domains (Reape, 1994, Kathol, 1995) to the domain of coordination (Blevins and Sag, 1996, Yatabe, 2000, 2003, Crysmann, 2000). In essence, the HPSG approaches to NCC appear to belong to what Maxwell and Manning (1996) called “a new breed of theories which allow non-constituent coordinations by effectively moving coordination up one level while maintaining classical notions of constituency.”

In this paper I will discuss the phenomenon of Conjunction Reduction and the kind of problems it poses for a linearisation-based treatment in HPSG. We will find that heads behave quite differently from dependents in this construction and show that a naive theory of peripheral sharing as unification of domain objects will run into systematic problems which cannot be easily resolved along the lines of feature indeterminacy. I will propose an asymmetric approach to head and dependent sharing which essentially constitutes a surface-oriented theory of reconstruction and show that this perspective will also obviate the need of generalisation or subsumption tests with Coordination of Unlikes.

1.2 Word order domains and coordination: Some basic issues

It has been argued over the last decade that the description of linearisation in so-called free word order languages, such as German should best be stated at a level of structure that is considerably larger than immediate constituents: consequently Reape (1994) and Kathol (1995) have suggested to describe word order regularities at the level of a list-valued feature DOM that collects all major constituents along the head projection path. In essence, order domains offer a flat, linear representation of the main constituents, including complements, modifiers, as well as a representation of the lexical head. The detachment of word order domains from immediate constituency offers a convenient tool to implement a *shared-structure* approach (Milward, 1994) to peripheral sharing within HPSG.

It should come as no surprise that most attempts at a theory of NCC in HPSG build on the concept of order domains (Blevins and Sag, 1996, Yatabe, 2000, Crysmann, 2000), and unanimously exploit the same core idea, namely, that in the course of complex domain formation in coordinate structures peripheral domain objects can be collapsed into one, under unification. A similar idea was developed in Kathol (1995) to account for SGF-coordination in German. Yatabe (2000) explicitly relates the phenomenon of peripheral sharing to that

¹See Levy and Pollard (2001) for a detailed comparison, suggesting formal equivalence of set-based and type-based approaches.

of extraposition.

A linearisation-based theory of peripheral sharing typically makes two basic assumptions: first, that unifiable domain objects can be collapsed under token-identity, and, second, that non-shared domain objects cannot be interleaved. Owing to the monotonicity of the shuffle operation (\circlearrowleft) used for domain construction, ordering within each conjunct will be preserved in the order domain of the coordinate structure. Thus, it will be possible to identify peripheral elements solely in terms of their linear position on the DOM-list of each conjunct daughter. In order to prevent interleaving of non-shared domain objects on the DOM-list of the entire coordinate structure (see the examples in (3)), Yatabe (2000) and Crysmann (2000) suggest partial compaction of the non-shared rest, an operation familiar from Kathol's (1995) approach to relative clause extraposition: basically, the non-shared domain objects of each conjunct are compacted into a single domain object on the DOM-list of the mother.

- (3) a. * John gave Mary a book and a record on Wednesday on Tuesday.
 b. * John gave Mary a book a record and on Wednesday on Tuesday.
 c. * John gave Mary a book and a record on Wednesday and on Tuesday.

Under these accounts, the phonological contribution of this domain object is derived by means of concatenation of the compacted domain objects, with categorial information being constructionally assigned by the surrounding coordinate structure.

$$\begin{array}{c}
 \left[\begin{array}{l} \textit{phrase} \\ \text{DOM} \quad \boxed{1} \oplus \left\langle \left[\begin{array}{l} \text{PH} \quad \boxed{i_1} \oplus \dots \oplus \boxed{i_m} \oplus \boxed{j_1} \oplus \dots \oplus \boxed{j_n} \\ \text{SS} \mid \text{L} \mid \text{CAT} \quad \boxed{0} \end{array} \right] \right\rangle \\ \text{SS} \mid \text{L} \mid \text{CAT} \quad \boxed{0} \left[\begin{array}{l} \text{HD} \quad \textit{verb} \\ \text{SUBJ} \quad \langle \rangle \end{array} \right] \end{array} \right] \\
 \hline
 \left[\begin{array}{l} \textit{phrase} \\ \text{DOM} \quad \boxed{1} \oplus \boxed{2} \left\langle \left[\text{PH} \quad \boxed{i_1} \right], \dots, \left[\text{PH} \quad \boxed{i_m} \right] \right\rangle \\ \text{SS} \mid \text{L} \mid \text{CAT} \quad \boxed{0} \end{array} \right] \quad \left[\begin{array}{l} \textit{phrase} \\ \text{DOM} \quad \boxed{1} \oplus \boxed{3} \left\langle \left[\text{PH} \quad \boxed{j_1} \right], \dots, \left[\text{PH} \quad \boxed{j_n} \right] \right\rangle \\ \text{SS} \mid \text{L} \mid \text{CAT} \quad \boxed{0} \end{array} \right]
 \end{array}
 \tag{4}$$

As a side-effect, partial compaction will also solve the issue of inconsistent ordering within and across conjuncts: given standard semantics of LP constraints, a statement like the one in (5) would be violated, if we were to represent non-shared domain objects as such in the order domain of the entire coordinate structure.

- (5) NP[acc] \prec NP[to]
 ($\equiv \textit{sign} \rightarrow \neg [\text{DOM} \langle \dots, \text{NP}[\text{to}], \dots, \text{NP}[\text{acc}], \dots \rangle]$)
 (6) John gave a book *to Mary* and *a record* to Peter.

Partial compaction, however, renders the non-shared rest opaque, effectively guaranteeing consistent ordering.

To summarise, linearisation-based accounts of NCC try to capture the intuition that a structure featuring peripheral sharing is well-formed whenever the individual conjuncts are well-formed, provided a contiguous portion of the surface string is shared. Thus, under these theories, coordination targets fully saturated signs, i.e. feature structures where all internal subcategorisation requirements have already been fulfilled, and then merely collapses a peripheral sequence of domain objects in the linear representation of the coordinated structure.

1.3 Peripheral sharing and valence information: a problem

An aspect that has been glossed over by most domain-based approaches to NCC to date (e.g. Blevins and Sag, 1996, Crysmann, 2000, Yatabe, 2000) relates to the sharing of the head domain object in CR (or LNR/RNR) constructions: while the linearisation-based approach to CR in terms of shared peripheral domain objects gives sound results for dependents, the coordination schema given above actually breaks, if the non-shared dependents differ with respect to their semantics. The reason is that the head domain object specifies, on its valence lists, relations to both shared and non-shared dependents. With shared dependents, no problem may arise, as they are, by necessity, coreferent across the two conjuncts. For non-shared dependents, however, the head domain objects contributed by each conjunct will have differing CONT values on their valence lists.

- (7) John gave Mary a book on Wednesday and several records on Saturday.

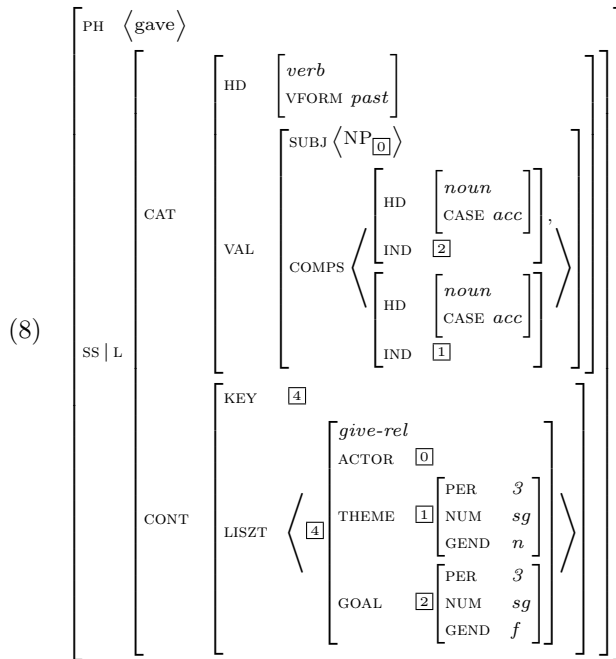

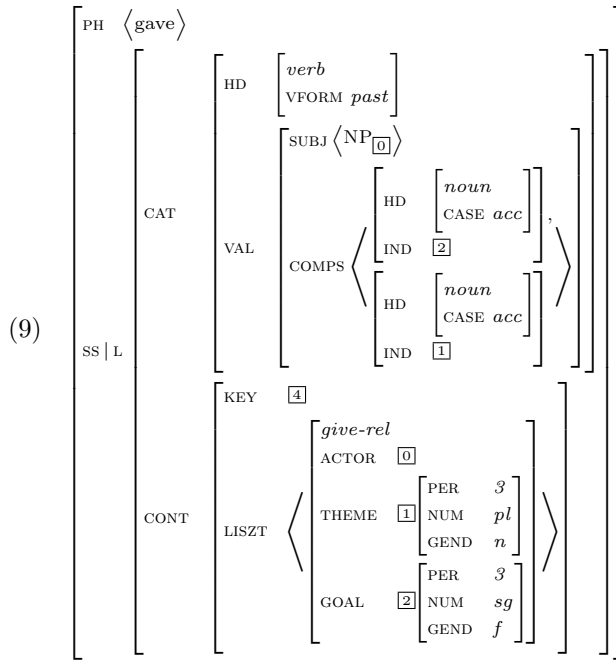

To make the problem a bit more apparent, let us consider a concrete example: in the above sentence, the head domain object contributed by the first conjunct will have a COMPS value as indicated in (8), i.e. requiring the second complement’s CONT—INDEX—NUM to be of type *sg*, whereas the head of the second conjunct will require its corresponding second complement to have a specification for *pl*, cf. (9).²

As a result, if the head is shared on the DOM list of the entire coordinated structure, simple token-identity of the domain objects will not do, due to a unification failure on the subcategorisation requirements for the second complement. Similarly, unification of the verbs’ CONT values will equally clash.

1.3.1 Semantic differences between heads and dependents

Thus, the first issue to be addressed is the question of what semantic interpretation we would want to assign to coordinated structures in which the head is shared. A closer look at (7) reveals that sharing of the entire domain object (and, hence its SYNSEM value) does not give sound results for the event semantics either. As the shared head *gave* is modified by a different temporal expression in either conjunct, it is clear that (7) actually denotes two independent giving events. Token-identity of the domain objects obviously gives the wrong result here, as it entails structure sharing of the event variable as well.³

²Certainly, difference in index features is not the only discrepancy that will arise here. Rather, the incompatibilities will affect the entire CONT-value, including semantic relations.

³The issue of token-identity of domain objects is pretty much independent of where exactly semantic composition will take place (which I take to be constituent structure): if SYNSEM values get unified on DOM, there is no way of undoing this effect anywhere else in the sign.

Thus, in semantic terms, sharing of heads differs quite drastically from sharing of dependents, where token-identity of CONT values is necessary to derive the correct interpretation:⁴

- (10) a. Few men drink and smoke.
 b. $\not\rightarrow$ Few men drink and few men smoke.
- (11) a. Few men gave Mary a book on Friday and a record on Saturday.
 b. $\not\rightarrow$ Few men gave Mary a book on Friday and few men gave Mary a record on Saturday.
- (12) a. I gave few men a book on Friday and a record on Saturday.
 b. $\not\rightarrow$ I gave few men a book on Friday and I gave few men a record on Saturday.

Without token-identity of CONT values, we would give the above sentences in a. an interpretation equivalent to b., whereas structure-sharing will ensure that the sets denoted by *few men* are identical across the two conjuncts in the a. sentences, while they may be disjoint in the corresponding sentences in b. From this, we can conclude that, semantically, shared dependents and shared heads behave entirely different from another: as a consequence, we would want to equate the CONT values of the former, whereas we certainly do not want to do so for the latter. Thus, it seems to make perfect sense to relax the requirement concerning structure-sharing of the entire domain object in the case of heads, yet retain this requirement for dependents.

Now that we have established that sharing of the heads' CONT values in coordinated structures is undesirable for independent reasons, we can move on to the second issue, namely sharing of valence information.

1.3.2 Parallelism requirements

Although it is clear that the CONT specifications on the valence lists of the shared heads do not need to match up across the two conjuncts, we have to ask, of course, whether this is also true for any of the other information these heads subcategorise for, e.g. syntactic category and case. A piece of data that may bear on this point is given in (13) below: while speakers of English seem to be strictly divided as to the acceptability of this sentence, there is a considerable subset of speakers who utterly reject it.

- (13) (*) John gave Mary a book and a record to Peter.

⁴I will restrict myself here to a discussion of CR. What is clear, though, is that sharing in RNR cannot involve token-identity of entire head domain objects.

- i. We can but you can't come to his party on Friday.

Independent of what the exact empirical situation is for dependent sharing here, the asymmetric approach to be developed for CR should be flexible enough to accommodate either situation. Thus, if, with RNR, shared dependents are not necessarily coreferent across the conjuncts, a conclusion suggested by binding facts, it will be sufficient to impose the analogue of (18), as well as (19). However, I will reserve this phenomenon as a topic for future research.

However, as pointed out to me by Doug Arnold (p.c.), the following example featuring heavy NP-shift in the second conjunct is equally ruled out for him, despite the parallelism in subcategorisation frames.

- (14) * John gave a book to Mary and to Peter a very old and famous early Beatles' record featuring vocals by Ringo.

Similarly, Bob Levine (p.c.) remarks that (13) improves considerably, if surface order of theme and goal arguments match up across the two conjuncts:

- (15) John gave Mary a book, and to Peter, a record.

Thus, whatever causes (13) to be unacceptable for some speakers, it is certainly a factor unrelated to the mismatch in subcategorisation requirements. As argued by Whitman (2002), acceptability of the non-parallel cases improves, once a suitable context is provided.

- (16) Q: So Neal, did you give the dog that toy like you were planning to do?
 (17) A: No, actually I changed my mind. I gave the dog a bone, and the toy to the cat.

Taken together, all these data appear to indicate that the parallelism requirement should better be understood in terms of information structure, rather than in terms of strictly parallel subcategorisation frames. Moreover, even if one wished to impose a restriction as to the parallelism in category and case of non-shared valencies, the VAL feature of the shared head is surely not the only locus where such a constraint could be expressed: alternatively, the parallelism may equally well be captured as a constraint on the DOM lists of the conjoint daughters. Such a solution will not only be more flexible but also feature the additional benefit of offering an explanation for the data in (14) concerning heavy NP shift.

1.3.3 Some suboptimal solutions

Having established now that parallelism of valencies is not an intrinsic property of head sharing, we have to address the issue how VAL features should be composed in CR. A quick and presumably quite dirty fix to the incompatibility of subcategorisation requirements would be to assume that the valence lists of the shared head domain object are the generalisation, rather than the unification of the valence lists of the corresponding domain objects on each conjunct. To say the least, such a solution would stand in sharp contradiction to the assumption that the feature structures modelled by an HPSG theory are required to be totally well-typed and sort-resolved. Moreover, outside the domain of coordination, use of this operation is marginal at best, if not entirely unattested. The only exception to be found is Daniels's (2001) account of Coordination of Unlikes. However, as we will see shortly, our asymmetric theory of head and dependent sharing will provide a solution here as well.

Another, probably equally bad, solution would be to concatenate, rather than unify the valence lists. Certainly, such a move is pretty ad hoc and devoid of any deeper linguistic motivation. Worse, as conflict is not limited to the valence

lists, but also affects ARG-ST, concatenation would have to be replicated here as well. This, however, will interfere quite badly with Binding Theory, or, more precisely, the obliqueness command relationship represented in this feature.

A third alternative has been proposed in Yatabe (2003): here, the valence lists are composed component-wise creating a conjoint subcategorisation requirement. Although this is a technically viable solution, it introduces a new species of entities into the domain of subcategorisation: Outside the area of peripheral sharing, however, specific subcategorisation for distributive conjoint dependents is both unattested and unnecessary. Furthermore, even within Yatabe’s system it is unclear what role these conjoint subcategorisation requirement should play besides the obvious reason to avoid unification clashes on the valence list of the shared head domain object: as subcategorisation requirements are satisfied within each conjunct individually, it appears that this new type of conjoint synsem object is fully redundant and, as such, does not really contribute to our understanding of the linguistic issue at stake.

1.4 An asymmetric approach to head/dependent sharing

Instead, I will pursue an essentially asymmetric approach to head sharing: while dependents will require token-identity between the shared domain object on the DOM list of the mother and the corresponding domain objects in either conjunct, with heads, the entire domain object on the mother will be structure-shared with a corresponding domain object in a single conjunct only. Token-identity of PHON and HEAD values, however, is obligatory for all shared material across all conjuncts, irrespective of the head-dependent divide.

The intuition underlying this approach pertains to the observation that CR structures can be divided into a continuous string, which corresponds to the yield of the DOM list of the first conjunct, and a remainder, which only represents the right part of the domain structure of the second conjunct. Thus, it appears that the shared material on the DOM-list of the mother can actually be directly projected from the first conjunct, whereas it has to be “reconstructed” for the second.

Thus, we can establish that left-peripheral sharing proceeds along three dimensions: identity of phonology and category across both conjuncts, projection of the entire domain object from the first conjunct, and token-identity of shared dependents across all conjuncts. We can implement these three different dimensions of sharing straightforwardly by means of three constraints.

The first constraint implements the minimal requirement that sharing in CR entails token-identity of phonologies. To avoid sharing of homophonous, though categorially distinct material, we can further demand identity of HEAD values.

$$(18) \left[\begin{array}{c} \textit{phrase} \\ \textit{DTRS } l\text{-shrd}\text{-coord}\text{-str} \end{array} \right] \rightarrow \left[\begin{array}{c} \text{DOM} \left\langle \left[\begin{array}{c} \text{PH} \\ \text{HD} \end{array} \begin{array}{c} i_1 \\ h_1 \end{array} \right], \dots, \left[\begin{array}{c} \text{PH} \\ \text{HD} \end{array} \begin{array}{c} i_m \\ h_m \end{array} \right] \right\rangle \oplus \left\langle \left[\begin{array}{c} \text{PH } j_1 \oplus \dots \oplus j_n \oplus k_1 \oplus \dots \oplus k_o \\ \text{SS | L | CAT } \bar{0} \end{array} \right] \right\rangle \\ \text{SS | L | CAT } \bar{0} \left[\begin{array}{c} \text{SPR} \\ \text{SUBJ} \\ \text{COMPS} \end{array} \begin{array}{c} \langle \rangle \\ \langle \rangle \\ \langle \rangle \end{array} \right] \\ \text{CONJ-DTRS} \left\langle \left[\begin{array}{c} \text{DOM} \left\langle \left[\begin{array}{c} \text{PH} \\ \text{HD} \end{array} \begin{array}{c} i_1 \\ h_1 \end{array} \right], \dots, \left[\begin{array}{c} \text{PH} \\ \text{HD} \end{array} \begin{array}{c} i_m \\ h_m \end{array} \right] \right\rangle \oplus \left\langle \left[\begin{array}{c} \text{PH } j_1, \dots, \text{PH } j_n \right] \right\rangle \\ \text{SS | L | CAT } \bar{0} \end{array} \right], \\ \left[\begin{array}{c} \text{DOM} \left\langle \left[\begin{array}{c} \text{PH} \\ \text{HD} \end{array} \begin{array}{c} i_1 \\ h_1 \end{array} \right], \dots, \left[\begin{array}{c} \text{PH} \\ \text{HD} \end{array} \begin{array}{c} i_m \\ h_m \end{array} \right] \right\rangle \oplus \left\langle \left[\begin{array}{c} \text{PH } k_1, \dots, \text{PH } k_o \right] \right\rangle \\ \text{SS | L | CAT } \bar{0} \end{array} \right] \right\rangle \end{array} \right]$$

Besides, this constraint guarantees that sharing of phonologies can only involve contiguous peripheral stretches, in this case sharing at the left edge.

Projection of SYNSEM values from the DOM list of one of the conjuncts is given in (19). Here, all we have to do is specify that all domain objects except one on the DOM list of the entire coordinated structure are structure-shared with domain objects on one of the conjunct daughters. The single domain object that is exempt from this requirement is the compaction of the unshared domain objects, identified by means of the token-identity of its CAT value with that of the coordinated structure ($\bar{0}$).

$$(19) \left[\begin{array}{c} \textit{phrase} \\ \textit{DTRS } \textit{coord}\text{-struc} \end{array} \right] \rightarrow \left[\begin{array}{c} \text{DOM} \quad \bar{1} \quad \circ \left\langle \left[\text{SS | L | CAT } \bar{0} \right] \right\rangle \\ \text{SS | L | CAT} \quad \bar{0} \\ \text{CONJ-DTRS} \quad \left\langle \left[\text{DOM } \bar{1} \circ \textit{list} \right] \right\rangle \circ \textit{list} \end{array} \right]$$

As a last step, we can enforce sharing of the SYNSEM value of dependents across all conjuncts: this is achieved by ruling out any situation where there is a domain object with all-saturated valencies on the DOM list of the mother that fails to be structure-shared with a domain object on any of the conjunct daughters. Again, the single domain object that holds the compacted non-shared rest is exempted from this requirement.

$$(20) \left[\begin{array}{c} \textit{phrase} \\ \textit{DTRS } l\text{-shrd}\text{-coord}\text{-struc} \end{array} \right] \rightarrow \left[\begin{array}{c} \text{DOM} \quad \left\langle \left[\begin{array}{c} \bar{1} \\ \text{SS | L | CAT | VAL} \end{array} \left[\begin{array}{c} \text{SUBJ} \\ \text{SPR} \\ \text{COMPS} \end{array} \begin{array}{c} \langle \rangle \\ \langle \rangle \\ \langle \rangle \end{array} \right] \right] \right\rangle \circ \left\langle \left[\text{SS | L | CAT } \bar{0} \right] \right\rangle \circ \textit{list} \\ \neg \\ \text{SS | L | CAT} \quad \bar{0} \\ \text{CONJ-DTRS} \quad \left\langle \neg \left[\text{DOM} \quad \langle \bar{1} \rangle \circ \textit{list} \right] \right\rangle \circ \textit{list} \end{array} \right]$$

As such, the technical implementation of the analysis proposed has all the necessary properties identified above: the constraint in (20) is capable of deriving that shared dependents are necessarily interpreted as coreferent, accounting for the contrasts in (10–12). Shared heads, however, are subject to a somewhat weaker constraint that only requires token-identity with a domain object in one of the conjuncts. Still, projecting SYNSEM information of heads from a single conjunct ensures that the corresponding domain object on the mother will contain sufficiently rich information such that order constraints that hold on each of the conjuncts can be satisfied identically on the DOM list of the mother: as the only domain objects transparently represented on the mother are shared heads and shared dependents, and the shared dependents are actually required to be token-identical to those in all the conjuncts, it is clear that even the valency information for shared dependents will be structure-shared on the VAL features of the head, despite the fact that the SYNSEM value of this head is only projected from a single conjunct. The only place where projection from a single conjunct makes a difference is the representation of non-shared dependents. However, for linearisation purposes this does not matter at all, as non-shared dependents are not transparently represented on the DOM list of the entire structure anyway, but rather, they are compacted into a single opaque domain object.

1.4.1 Some qualifications re dependent sharing

On closer examination one will observe that even dependents are not all created equal: while the sentences in (21a) and (21b) below necessarily demand identity of individual real-world referents for the (animate) theme or goal argument, the sentence in (21c) can only be interpreted, given world knowledge, in the sense that at least two separate copies of some letter have been posted to their respective destinations.

- (21)
- a. Mary sent a friend a letter on Friday and a postcard on Saturday.
 - b. I introduced a friend to the head of department on Thursday and to the dean on Friday.
 - c. Mary sent a letter to Bill on Friday and to Peter on Saturday.
 - d. ? A letter was posted from Gozo last Saturday and from Tunis this week.

Interestingly enough, this division appears to be independent of both grammatical function and syntactic position: passives, like the one in (21d) above do not pattern all too differently in this respect.

The shared dependents in (21c) or (21d) still require similarity of the letters, e.g. with respect to contents. Apparently, this restriction is beyond what is captured by mere identity of the type of semantic relation. Thus, I would rather interpret these facts as an instance of coercion of *letter* to an abstract notion (which is token-identical across the two conjuncts) that happens to have more than one concrete physical instantiation. Coercion to a single abstract referent, however, can only be enforced, if we impose token-identity syntactically. As a result, the asymmetry between animate dependents, as in (21a,b) and inanimate

ones, as in (21c,d) will be related to the ease or difficulty with which such an abstract referent can be given.

But can we also find empirical support for this hypothesis? That is, will shared dependents only receive a distributive interpretation as a result of coercion? A conclusive piece of evidence may be found in the context of intersective modification. As we have observed above, sharing of verbal heads in CR constructions does not entail sharing of event variables. As a consequence, these distinct event variables can easily be modified by different temporal modifiers.

(22) John gave Mary a book on Wednesday and several records on Saturday.

Shared dependents, however, do not seem to pattern with heads in this respect:

- (23) a. ?? An email was posted on Friday from an account in China, advertising Viagra, and on Saturday from the States, offering age-reversal remedies.
 b. ? Some bulk mailer sent an email from an account in China, advertising Viagra, and from the States, offering age-reversal remedies.

Modification of a shared dependent by different intersective modifiers makes the entire construction awkward, if not unacceptable.⁵ Under the assumption that dependent sharing does indeed involve sharing of indices, the unacceptability of the above sentences can readily be explained: if the indices are shared, both modifiers will target one and the same individual variable. Coercion to some abstract notion of bulk email cannot apply in this case, owing to the simple fact that the conflicting modifiers render the interpretation highly specific.

Before we close the discussion of dependent sharing, I would like to address an apparent counter-example to the hypothesis advanced here, brought up by Shalom Lappin (p.c.).

(24) She saw most films in Cannes this year and in Venice last year.

Here, the most likely interpretation is clearly a distributive one. But does the above sentence really constitute counter-evidence to the claim raised here? To decide upon this, we first need to establish that we are actually dealing with an unambiguous case of conjunction reduction at the sentential level. Attachment of the spacial modifiers, however, is systematically ambiguous between modification of the event and modification of the direct object. Under the salient

⁵The degree of acceptability enjoyed by the examples in (23b) above is evidently much higher than that of the corresponding example in (23a). The way I interpret these facts is that in b., but not in a. the verb provides an additional target for modification by the gerund. Once we control for this possibility, e.g., by choosing a relative clause, the acceptability soon degrades.

- i. Some bulk mailer sent an email from an account in China, which advertised Viagra, and another one from the States, which offered age-reversal remedies.
 ii. ?? Some bulk mailer sent an email from an account in China, which advertised Viagra, and from the States, which offered age-reversal remedies.

distributive interpretation, however, the locative modifiers *in Cannes* and *in Venice* are part of the quantifier’s restrictor. Similarly, the temporal expressions most probably modify the understood festival, and not just the seeing event. This perspective is also supported by syntactic facts, see (25) below.

- (25) Most films in Cannes this year and in Venice last year were actually quite boring.

Thus, what looks superficially like an instance of Conjunction Reduction at the sentential level turns out to be better understood as CR at the NP (or DP) level. Within the NP, the quantifiers are definitely semantic and, arguably, syntactic heads. Assuming a DP approach, the apparent counter-example can be reduced to a case of head-sharing CR in the nominal domain.

1.4.2 Peripheral sharing and argument composition

The asymmetrical approach to head/dependent sharing also provides a straightforward account of argument composition verbs taking wide scope over a coordination of complements. As argued by Abeillé and Godard (1994), classical constituency tests provide little or no evidence in favour of a VP constituent in French auxiliary-participle constructions. Instead, they suggest that French auxiliaries form a flat constituent structure with their participial complement, realising all of the complement’s arguments as its own complements.

$$(26) \left[\begin{array}{c} \text{SS} \mid \text{LOC} \\ \left[\begin{array}{c} \text{CAT} \\ \text{ARG-ST} \left\langle \begin{array}{c} \text{HEAD} \quad \textit{verb} \\ \text{[1], V} \end{array} \right\rangle \left[\begin{array}{c} \text{VFORM} \quad \textit{past-p} \\ \text{CONT} \quad \text{[3]} \\ \text{ARG-ST} \quad \langle \text{[1]} \oplus \text{[2]} \rangle \end{array} \right] \oplus \text{[2]} \\ \text{CONT} \quad \text{[3]} \end{array} \right] \end{array} \right]$$

Argument composition also provides the key mechanism in HPSG accounts of French cliticisation (Miller and Sag, 1997): as argued convincingly by Miller (1992), French pronominal clitics much more resemble lexical affixes than true post-lexical clitics. In particular they display a high degree of selection towards their host, they feature arbitrary gaps in the set of clitic and clitic-host combinations, and they are subject to morphophonological and semantic idiosyncrasies. Nevertheless, they sometimes get realised on a host they are not strictly an argument of, a phenomenon referred to as clitic climbing. Miller and Sag (1997) crucially build on argument composition in deriving non-local realisation of pronominal affixes in a lexicalist fashion.

Coordination data like the one in (27) are probably the only evidence one may find in favour of French auxiliaries taking a VP complement. However, Abeillé and Godard (1994) point out that these data may equally well be understood as an instance of CR. Manning (1997), by contrast, argues that a CR account of argument composition verbs is not entirely straightforward, as the auxiliaries to be shared may differ with respect to their (inherited) argument structure.

- (27) a. Paul a parlé avec Marie et compris son erreur.
Paul has spoken with Marie and understood his mistake

- ‘Paul has spoken with Marie and understood his mistake.’ (Abeillé and Godard, 1994, p. 159)
- b. Paul est arrivé à dix heures et reparti à midi.
Paul is arrived at 10 o’clock and left at noon
‘Paul arrived at 10 o’clock and left again at noon.’ (Abeillé and Godard, 1994, p. 159)
- (28) a. Paul l’a insulté et mis à la porte.
Paul him.has insulted and set to the door
‘Paul insulted him and threw him out.’ (Manning, 1997, p. 9)
- b. La bonne femme les a cuit au four et fait manger à son
the woman them has cooked in.the oven and made eat to her
fils.
son
‘The woman has cooked them in the oven and had her son eat them.’
(Manning, 1997, p. 9)

(28) obviously presents a challenge to the theories of Abeillé and Godard (1994) and Miller and Sag (1997): on the one hand, placement of the pronominal affix appears to necessitate argument composition, whereas raising of all arguments other than the affixal argument would give rise to unification failure, if sharing of the auxiliary required token-identity of the shared auxiliary across both conjuncts.⁶

Under the asymmetric approach to head/dependent sharing that we have developed above, however, no conflict will arise, as the auxiliary’s domain object on the DOM list of the mother need only be token-identical to the corresponding domain object on one of the conjuncts. Likeness of the heads being shared is attributed instead to token-identity of PHON and HEAD values. Again, just like in the English cases discussed earlier, this approach also gives sound results from the point of view of semantics: as witnessed by (27b), sharing of the tensed auxiliary does not entail identity of the event.

1.4.3 Coordination of Unlikes

Probably the only phenomenon which appears to require a generalisation operation or subsumption tests as part of the HPSG formalism is Coordination of Unlikes (cf. the Weak Coordination Principle in Pollard and Sag, 1994), a position that is shared by almost every approach to the issue (Blevins and Sag, 1996, Daniels, 2001, Sag, 2003).

(29) Pat is [[a Republican] and [proud of it]].

Given the standard model-theoretic interpretation of an HPSG theory, generalisation is not entirely unproblematic (see Pollard and Sag, 1994), in that the feature structures denoted by the generalisation will not be totally well-typed

⁶Here, the situation is even worse than in the English examples discussed above, as the valence lists may even differ in length.

and sort-resolved.⁷ The proposal by Daniels (2001) represents an exception to this, in that a “coordination type”, such as *acc+dat* not only subsumes the two types *acc* and *dat* it is the generalisation of, but also immediately subsumes a maximal type *p-acc+dat*, a “pure type” in Daniels’ terminology. Independent of the formal ramifications of subsumption tests and/or generalisation, it is clear that introducing a specific operation for a single construction only does not exactly reflect standard ideas about scientific economy. In other words, a theory of language that can be cast entirely in terms of unification certainly makes a much stronger claim.

In the domain of CR, we have already seen that potential unification clashes simply do not arise, once we adopt a slightly different perspective on the data, namely in terms of an asymmetric surface-oriented theory of reconstruction. Ever since Sag et al. (1985), the underlying intuition was that what makes Coordination of Unlikes acceptable is that each conjunct is actually well-formed when combined individually with the shared rest. In essence, this characterisation of Coordination of Unlikes is highly reminiscent of, if not identical to the one we would give for NCC. Thus, it will be worthwhile to pursue whether coordination of unlikes should not be better understood as a case of CR.

Under this perspective, the auxiliary will combine independently with an NP or AP in each conjunct, thereby guaranteeing that subcategorisation requirements are always met. Coordination, however, will apply at the level of sentential signs. According to our asymmetric theory of CR detailed above, the DOM list of the entire coordinate structure will consist of a single domain object, which is the compaction of the non-shared strings from both conjuncts, preceded by a list of domain objects. The HEAD and PHON values of these domain objects are constrained to be token-identical to those of the initial domain objects in both conjuncts. Furthermore, our constraint in (19) requires that each domain object on this list corresponding to shared material must be unified as a whole with the corresponding domain objects in the first conjunct, essentially warranting that DOM-LIST of the mother will always be a list of total objects projected from that conjunct which is realised as a contiguous string. Furthermore, for shared dependents, our theory of CR demands unification of entire domain objects across all conjuncts. Applied to the example above, we will find that the valencies of the head auxiliary are already satisfied, and therefore cancelled off, at the point where the phrases combine into a coordinated constituent. Thus, at the level of constituent structure, no conflict can ever arise. At the surface-syntactic level, however, it is exactly valence information relating a shared head to non-shared dependents that provides the source of the conflict, a situation which is fully identical to the one we identified with CR. Our asymmetric theory of reconstruction, however, specifically exempts the head domain object from the stricter requirement of total token-identity across both conjuncts, and limits identity requirements to those features which are necessary to perform

⁷See, however, Sag (2003) for a proposal to do away with sort-resolvedness entirely and regard as the model of a feature structure description the most general satisfier.

reconstruction.⁸ To conclude, we find that a simple change in the linguistic perspective enables us to reduce the issue of coordination of unlikes to head-sharing in CR, a phenomenon for which a unification-based solution has already been developed independently.

1.5 Conclusion

In this paper I have suggested an asymmetric surface-oriented theory of reconstruction for Conjunction Reduction (CR) and similar phenomena which obviates, by virtue of a change in linguistic analysis, the need for any special extensions to the underlying unification-based formalism or its model-theoretic interpretation. I have argued that the problem of conflicting CONT values between parallel dependents of a shared head is a distinguishing property of coordinated structures: if the phonological and syntactic representation of a dependent is shared across two conjuncts, it entails identity of semantic information. Heads, however, preserve the potential to distribute over the two conjuncts. I have shown that an adequate account of the semantics of CR favours an asymmetric approach that identifies the shared domain objects on the mother with a sublist of the domain objects of a single conjunct daughter. Dependents, however, observe a stronger restriction, involving token-identity of the domain objects across all conjunct daughters. This latter requirement is sufficient to derive the effect of obligatory coreference of shared dependents.

Furthermore, I have shown that the problem unification-based theories typically face when confronted with Coordination of Unlikes can be avoided, once these constructions are conceived of as a special case of Conjunction Reduction.

I further conjecture that the present asymmetric theory of head and dependent sharing can also be extended quite straightforwardly to cover gapping, the only difference being the mode of indexing. With Conjunction Reduction (and Right Node Raising), potentially shared material is identified by linear position, whereas grammatical function (most notably headhood) will provide the relevant concept in case of gapping. However, despite this difference, it appears that the asymmetric approach — in particular, the relaxation of identity requirements for head domain objects — will provide the necessary prerequisite for permitting shared heads to combine with different dependents in either conjunct. Such an account of gapping can then be understood as a linearisation- and unification-based variant of the type of Categorical Grammar analysis proposed by Steedman (1990).

References

Abeillé, Anne and Danièle Godard. 1994. The complementation of French auxiliaries.

⁸Throughout this paper I have contented myself with regarding phonology and basic category as sufficient to fulfil the recoverability demands. Subject to one's sense of humour, the following piece of data may suggest that we want to include the basic semantic relation under SYNSEM—LOC—CONT—KEY—RELN as well:

- i. ?? John grew potatoes and weary of it.

- In *West Coast Conference on Formal Linguistics*, no. 13. Stanford: CSLI Publications/SLA.
- Bayer, S. 1996. The coordination of unlike categories. *Language* 72(3):579–616.
- Bayer, S. and M. Johnson. 1995. Features and agreement. In *Proceedings of the 33rd Annual Meeting of the ACL*, pages 70–76.
- Blevins, James P. and Ivan Sag. 1996. Constituent sharing in nonconstituent coordination. ms., University of Alberta and Stanford University.
- Crysmann, Berthold. 2000. Clitics and coordination in linear structure. In B. Gerlach and J. Grijzenhout, eds., *Clitics in Phonology, Morphology and Syntax*, vol. 36 of *Linguistik Aktuell/Linguistics Today*, pages 121–159. John Benjamins.
- Dalrymple, Mary and Ron Kaplan. 2000. Feature indeterminacy and feature resolution. *Language* 76(4):759–798.
- Daniels, Michael. 2001. On a type-based analysis of feature neutrality and the coordination of unlikes. In *Proceedings of the 8th International Conference on Head-Driven Phrase Structure Grammar*, CSLI Online Proceedings, pages 137–147. Stanford: CSLI Publications.
- Ingria, R. J. P. 1990. The limits of unification. In *Proceedings of the 28th Annual Meeting of the ACL*, pages 194–204.
- Kathol, Andreas. 1995. *Linearization-Based German Syntax*. Ph.D. thesis, Ohio State University.
- Levy, Roger and Carl Pollard. 2001. Coordination and neutralization in HPSG. In *Proceedings of the 8th International Conference on Head-Driven Phrase Structure Grammar*, CSLI Online Proceedings, pages 221–234. Stanford: CSLI Publications.
- Manning, Christopher. 1997. Romance complex predicates: In defence of the right-branching structure. ms., University of Sydney.
- Maxwell, John T. and Christopher Manning. 1996. A theory of non-constituent coordination based on finite-state rules. In M. Butt and T. H. King, eds., *Proceedings of the LFG96 Conference, Rank Xerox, Grenoble*, CSLI Online Proceedings. Stanford: CSLI Publications.
- Miller, Philip. 1992. *Clitics and Constituents in Phrase Structure Grammar*. Outstanding Dissertations in Linguistics. New York: Garland.
- Miller, Philip and Ivan Sag. 1997. French clitic movement without clitics or movement. *Natural Language and Linguistic Theory* 15(3):573–639.
- Milward, David. 1994. Non-constituent coordination: Theory and practice. In *Proceedings of the Fifteenth International Conference on Computational Linguistics (COLING-94)*, pages 935–941.
- Pollard, Carl and Ivan Sag. 1994. *Head-Driven Phrase Structure Grammar*. Stanford: CSLI and University of Chicago Press.
- Reape, Mike. 1994. Domain union and word order variation in German. In J. Nerbonne, K. Netter, and C. Pollard, eds., *German in Head-Driven Phrase Structure Grammar*, no. 46 in Lecture Notes, pages 151–197. Stanford University: CSLI Publications.
- Sag, Ivan, Gerald Gazdar, Thomas Wasow, and Steven Weisler. 1985. Coordination and how to distinguish categories. *Natural Language and Linguistic Theory* 3:117–171.
- Sag, Ivan A. 2003. Coordination and underspecification. In J.-B. Kim and S. Wechsler, eds., *Proceedings of the 9th International Conference on Head-driven Phrase Structure Grammar, Kyung Hee University, Seoul, 5–7 August, 2002*. Stanford: CSLI Publications.

- Steedman, Marc. 1990. Gapping as constituent coordination. *Linguistics and Philosophy* 13:207–264.
- Whitman, Neil. 2002. *Category Neutrality: a Type-Logical Investigation*. Ph.D. thesis, Ohio State University.
- Yatabe, Shūichi. 2000. The syntax and semantics of left-node raising in Japanese. In *Proceedings of the 7th International Conference on Head-Driven Phrase Structure Grammar*, CSLI Online Proceedings, pages 325–344. Stanford: CSLI Publications.
- Yatabe, Shūichi. 2003. A linearization-based theory of summative agreement in peripheral-node raising constructions. In J.-B. Kim and S. Wechsler, eds., *Proceedings of the 9th International Conference on Head-driven Phrase Structure Grammar, Kyung Hee University, Seoul, 5–7 August, 2002*. Stanford: CSLI Publications.

